

Global Partner. Local Friend.

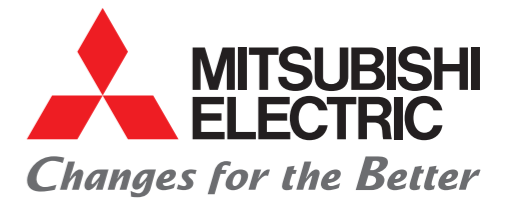

FACTORY AUTOMATION

MITSUBISHI ELECTRIC COLLABORATIVE ROBOT MELFA ASSISTA

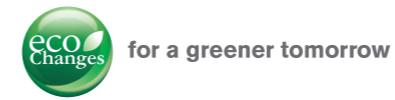
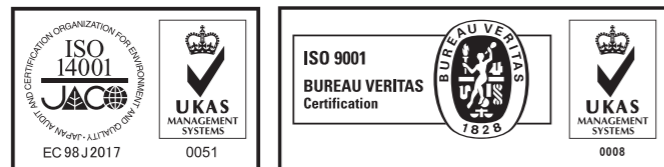
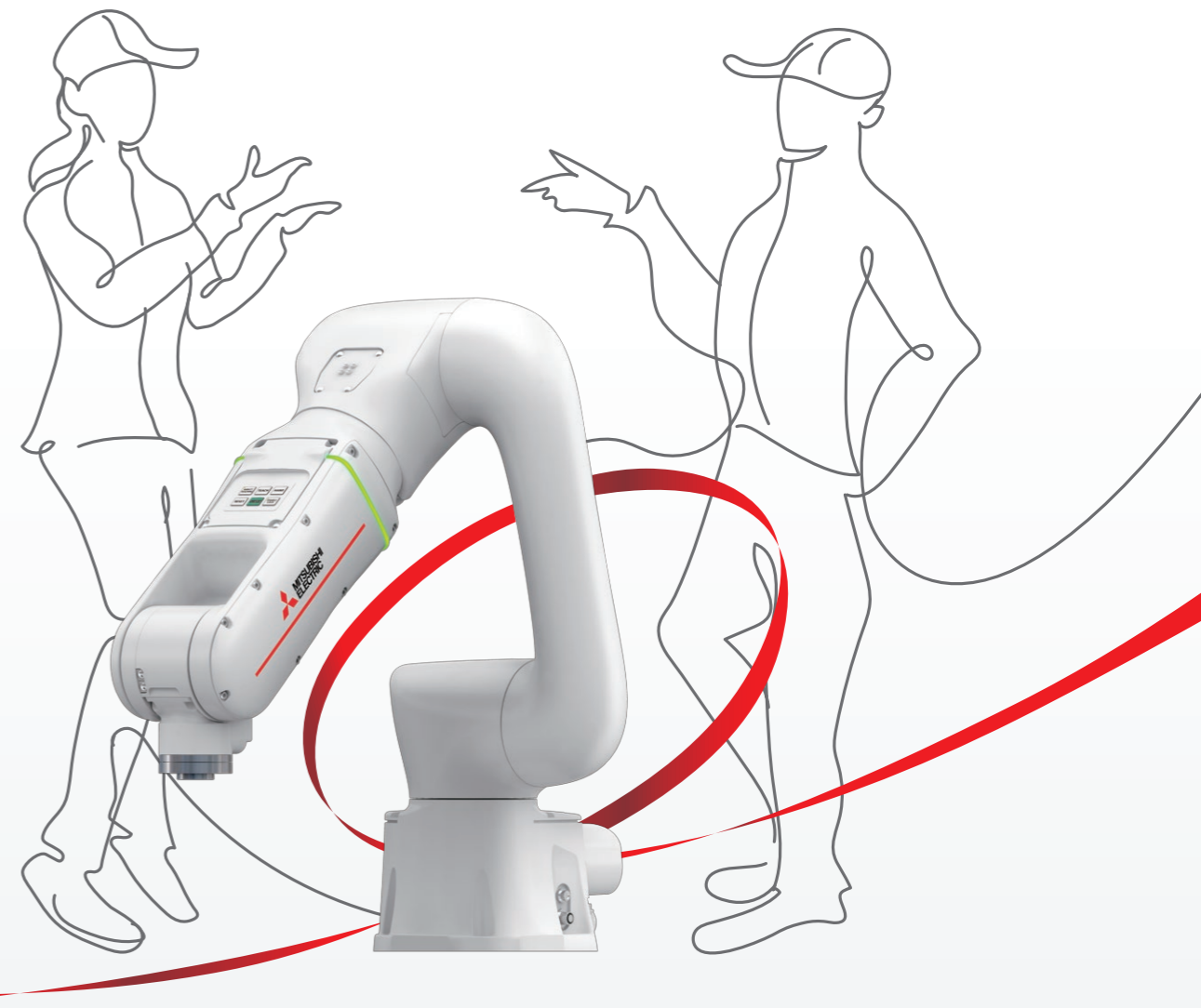

MITSUBISHI ELECTRIC CORPORATION HEAD OFFICE: TOKYO BLDG., 2-7-3 MARUNOUCHI,
CHIYODA-KU, TOKYO 100-8310, JAPAN

MELFA
assista

GLOBAL IMPACT OF MITSUBISHI ELECTRIC



Through Mitsubishi Electric's vision, "Changes for the Better" are possible for a brighter future.

Changes for the Better

We bring together the best minds to create the best technologies. At Mitsubishi Electric, we understand that technology is the driving force of change in our lives. By bringing greater comfort to daily life, maximizing the efficiency of businesses and keeping things running across society, we integrate technology and innovation to bring changes for the better.

Mitsubishi Electric is involved in many areas including the following:

Energy and Electric Systems

A wide range of power and electrical products from generators to large-scale displays.

Electronic Devices

A wide portfolio of cutting-edge semiconductor devices for systems and products.

Home Appliance

Dependable consumer products like air conditioners and home entertainment systems.

Information and Communication Systems

Commercial and consumer-centric equipment, products and systems.

Industrial Automation Systems

Maximizing productivity and efficiency with cutting-edge automation technology.

The new future of automation made possible by next-generation intelligent robots and e-F@ctory



Providing improvements in productivity, quality, environmental protection, safety and security to help reduce companies' TCO* and boost their corporate value

We offer solutions that use FA technology and IT to reduce total costs in everything from development through to production and maintenance, supporting customers to continuously improve their business operations and achieve truly cutting-edge manufacturing.

*TCO: Total Cost of Ownership

e-F@ctory is Mitsubishi Electric's trademark and registered trademark.

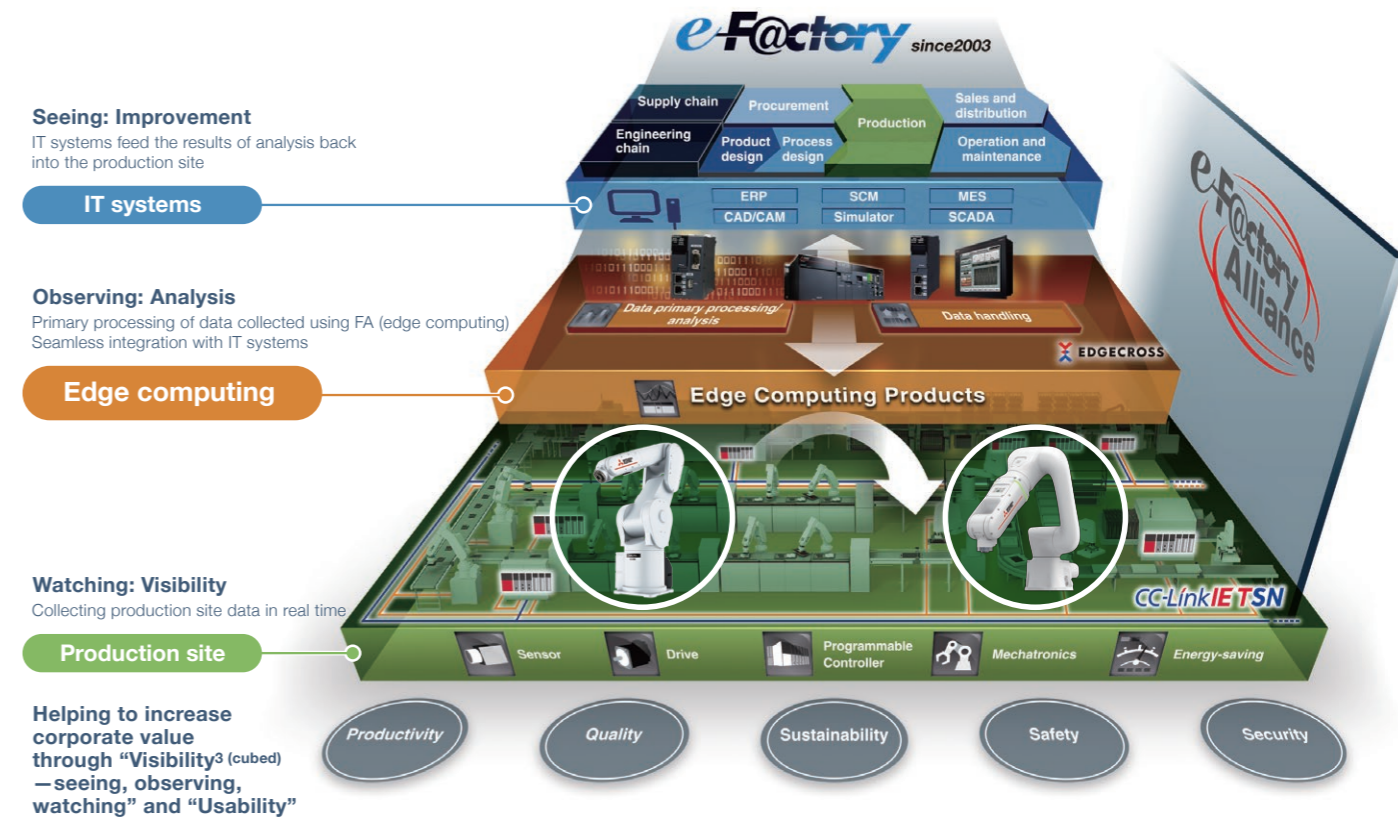

Integrate.

Collaborate.

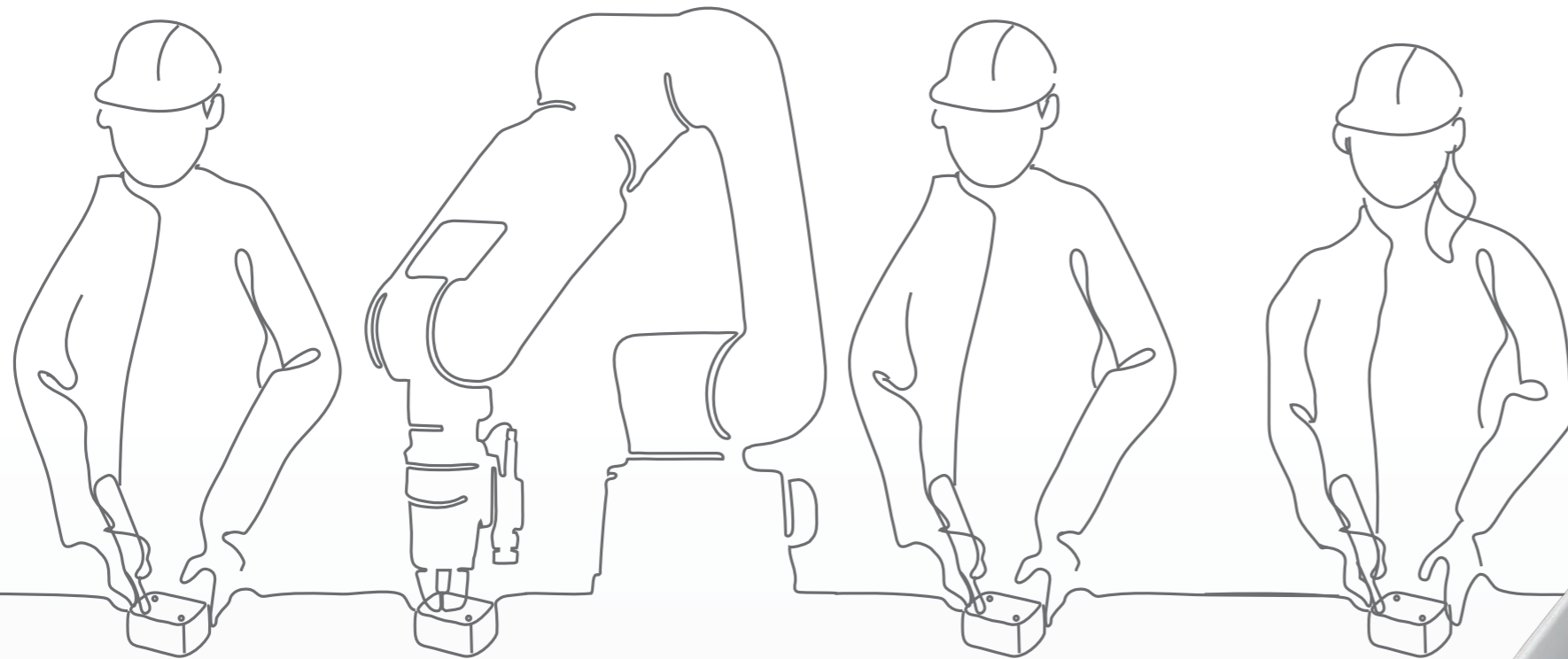

Mitsubishi Electric Collaborative Robot - ASSISTA

MELFA

as*!*ista

Simpler and Easier

No robot programming expertise required.

Easy Programming



Mitsubishi Electric Collaborative Robot - MELFA ASSISTA can share a workspace with humans. Simpler, Easier and more flexible. This robot will change your perception of what a "ROBOT" is.

MELFA

assist^a

Easy operation with the Operation button.

Easy Control



Easy connectivity with a wide variety of components.

Easy Connecting

Easy Control

Move Easily with
the Operating Buttons

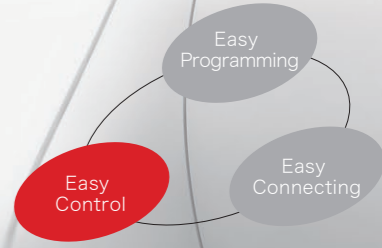

The operating buttons on the robot arm provide you with easy control for ASSISTA and the teaching pendant for programming and teaching is no longer needed. The LED on the robot arm display the status of the robot.

Easy Programming

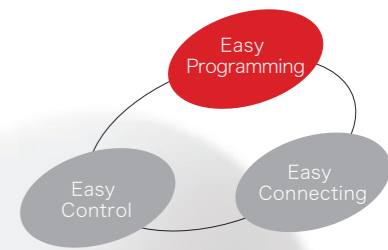

No Expertise
for Robot Required.

You can create programs visually using intuitive operations with RT-Visual-Box. "Visual Programming"
- This software allows operators to simply program this robot with a "train by demonstration" programming interface. This allows them to move the robot arm position and set way-points easily.



Easy Connecting

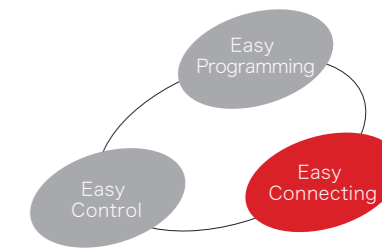

A Wide Variety of Components and Applications

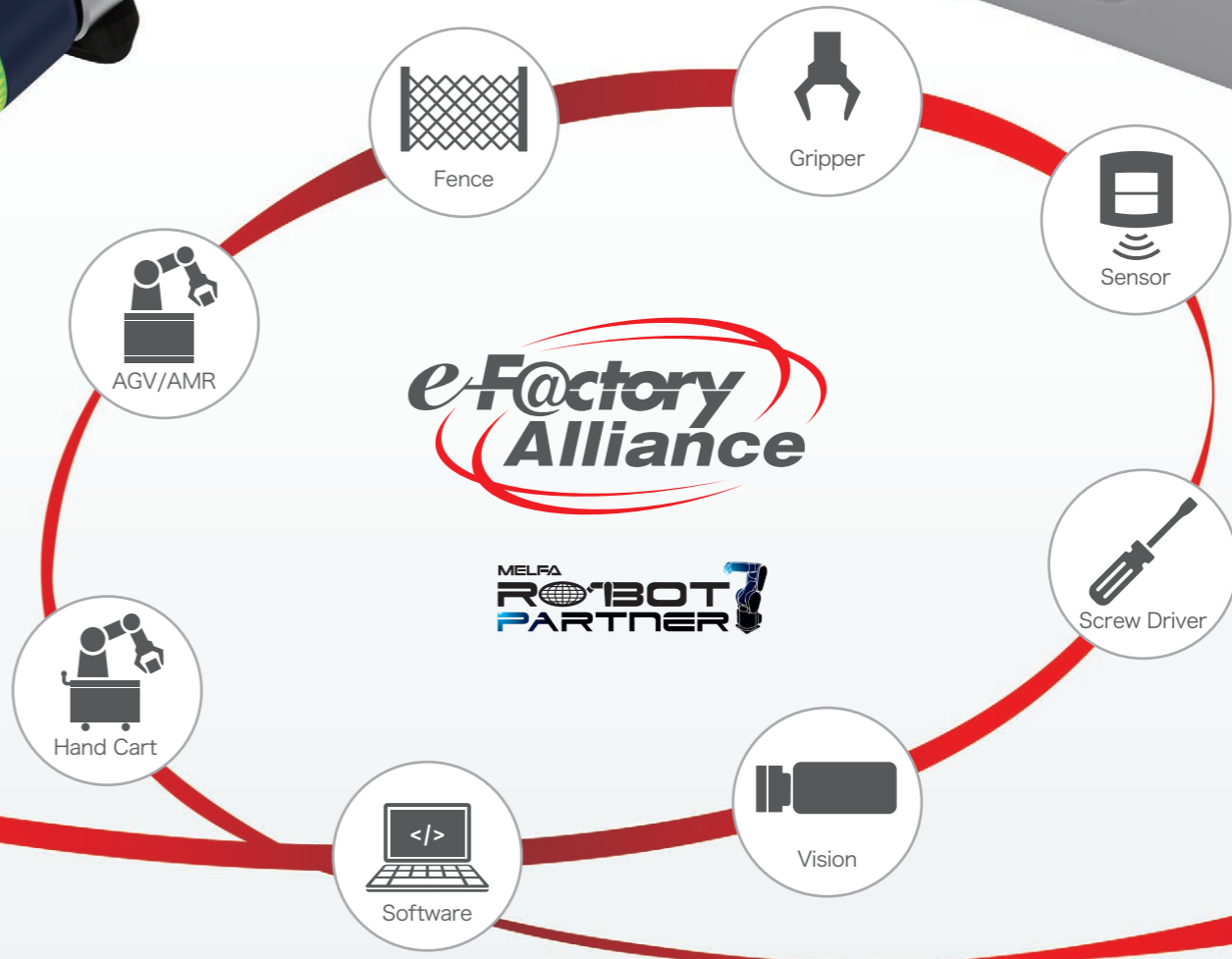

ASSISTA offers a wide variety of components—Grippers, Fingers, Vision and other peripherals—developed by a group of organizations known as MELFA Robot Partners. These tools can easily be setup and configured for your application. ASSISTA can also be configured to move freely as as part of an AGV/AMR or as a mobile robot.

AGV: Automated Guided Vehicle
AMR: Autonomous Mobile Robot

GRIP

with ASSISTA



Simply Connect Grippers to Robot Arm
 The ASSISTA Set-up wizard provides operators with an easier more intuitive methodology for gripper configurations.

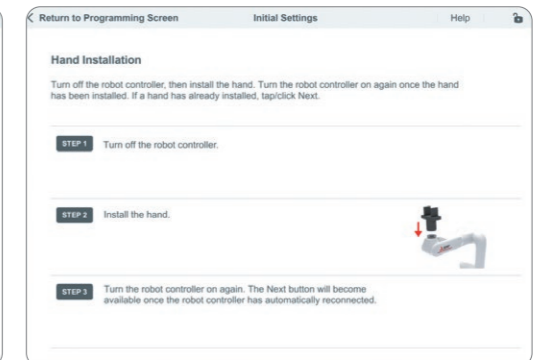

RT Visual Box (Engineering Software) lets operators set up grippers intuitively and easily.



Co-act EGP-C40 -N-N-ASSISTA(SCHUNK)
 Electric-powered Gripper

Weight: 885g (incl. attachments, fingers)
 Grip Force: 35N (min)/140N (max) (4 levels)
 Stroke: 6x2mm



HRC-03-099455 (Zimmer/Nabeya Bi-Tech Kaisha)
 Electric-powered Gripper

Weight: 916g (incl. attachments, fingers)
 Grip Force: 50N (min)/190N (max) (4 levels, adjustable to 140N)
 Stroke: 10x2mm



ROB-SET ECBPM ASSISTA(SCHMALZ)
 Electric-powered Adsorption Gripper

Weight: 631g (incl. attachments, adhesive pads)
 Vacuum Pressure: -60kPa, Flow rate: 1.6L/min

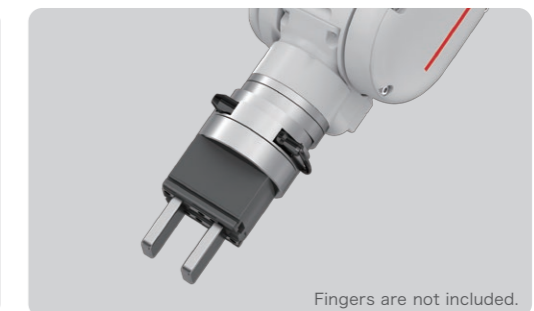

KIT-ASSISTA-G (GIMATIC)

Electric-powered Gripper (Gripper parts be prepared separately.)
 Weight: 922g (incl. attachments)
 Grip Force: 98N
 Stroke: 17.5x2mm

* These products may not be available in the region where you consider purchase. For details, please inquire at each company.

VIEW

with ASSISTA



ASSISTA and the camera capture the target using the “RT VisualBox” auto-focus function.

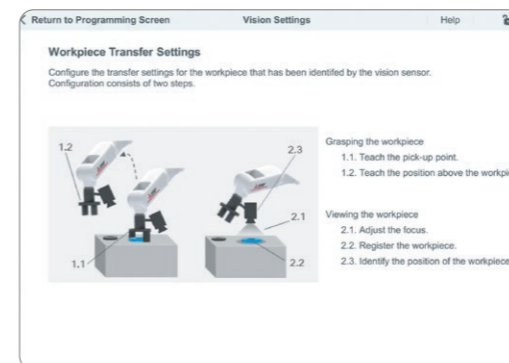

“RT VisualBox” proprietary engineering tool

The vision camera focus adjustment and work registration can be configured simply by touching the screen. This means that you can use it even without special robot knowledge.

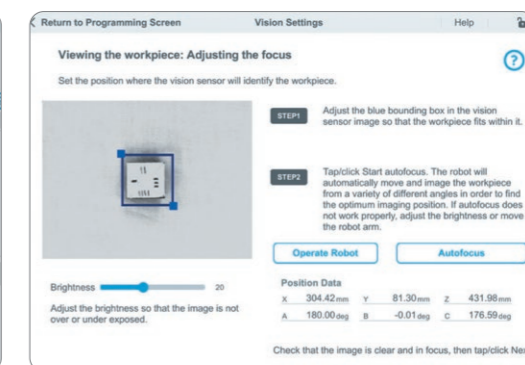
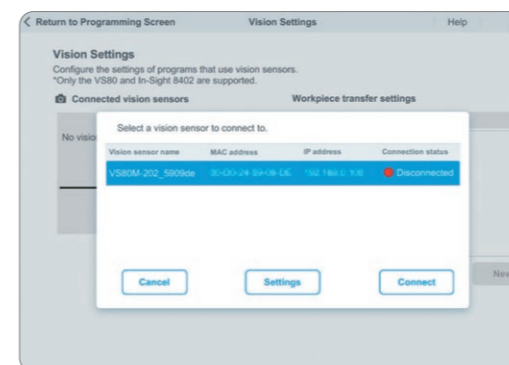

High-speed/High-precision
“PatMax RedLine®” built-in

Compact size/
Wire-saving type



Integrated camera with
all necessary functionality
embedded

Vision Sensor In-Sight

The high-performance camera identifies the target and fixes position at high speed. Its compact size makes it ideal for attaching to the ASSISTA robot hand. This wire-saving type is equipped with PoE.

Model Name	Manufacturer	Inquiries, (as of April 2020)	Comments
In-Sight 8402M-363-50	COGNEX	COGNEX	—
In-Sight 8402M-373-50	COGNEX	COGNEX	Supports PatMax RedLine® PatMax RedLine® cannot be used in combination with RT VisualBox

* These products may not be available in the region where you consider purchase. For details, please inquire at each company.

ASSISTA MOVES



You can freely move ASSISTA wherever needed whenever necessary.

The "AGV/AMR" unmanned transport cart secures the safety of various sensors and coexists with the operator. The company also provides a cart exclusively for use with ASSISTA, thereby enabling flexible response to changes in factory layout or the location where it is used.

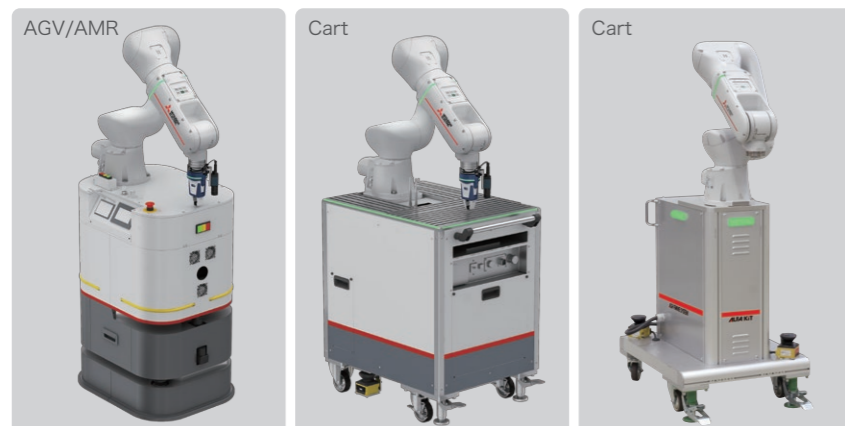

WYN700-MR-ASSISTA

HC-1-ASSISTA

AK-R-ASSISTA

WYN700-MR-ASSISTA (Tanabe Engineering Corporation)

Size W558 x D688 x H1000
(including bumper)
*Reference values for AGV unit excluding robot
Weight Approx. 260kg
*Reference values for AGV unit excluding robot

HC-1-ASSISTA (Satori Electric Co., Ltd.)

Size W600×D780×H910mm
Weight Approx. 240kg

AK-R-ASSISTA (NIC Autotec, Inc.)

Size W600×D900×H900mm
Weight Approx. 95kg

* These products may not be available in the region where you consider purchase. For details, please inquire at each company.

List of Collaborative Robot Partners

Gripper



SCHUNK Intec. K.K.

SchUNK offers the most extensive lineup of compact grippers and all-purpose grippers in the industry, and has full range of accessories for the perfect match between arms and tools, thereby enabling it to support the most diversified of needs.

Contact (Japan)

Minami-Shinagawa JN Bldg. 1F, 2-2-13, Minami-Shinagawa, Shinagawa-ku, Tokyo, 140-0004, Japan
Int: +81-3-6451-4321/Fax: +81-3-6451-4327
e-Mail: info@schunkjapan.jp

Contact (Europe)

SCHUNK GmbH & Co. KG
Bahnhofstraße 106-134, D-74348 Lauffen/Neckar, Germany
Tel.: +49-7133-103-0
e-Mail: info@de.schunk.com

Contact (China)

SCHUNK Intec Precision Machinery Trading (Shanghai) Co., Ltd.
Xinzhuang Industrial Park,
1F Building 1, No. 420 Chungong Road, Minhang District
Shanghai 201108
Tel. +86-21-54420007
e-Mail: info@cn.schunk.com

Contact (North America)

SCHUNK Intec Inc.
211 Kitty Hawk Drive Morrisville, NC 27560
Tel. +1-919-572-2705
e-Mail: info@us.schunk.com

This two-clawed parallel electric gripper is manufactured exclusively for collaborative robots, and compliant with safety standard ISO/TS 15066. Its LED status display enables simple status monitoring in the field. The durable design includes 4-stage grip force adjustment.



Dedicated Model

Model Co-act EGP-C40 N-N-Assista
Weight 885g (including attachments and fingers)
Stroke 12mm (Single-claw stroke 6mm x 2)
Grip Force 35N, 70N, 105N, 140N (adjustable within 4 stages)



**ZIMMER/
Nabeya Bi-tech Kaisha**

As an authorized distributor for Zimmer products in Japan, it offers a vast lineup of air grippers/electric grippers with high grip force (maximum 1800N).

Contact (Head Office)

1-banchi, Toukoudaich, Seki-shi, Gifu Prefecture, 501-3939, Japan
Int: +81-5-7523-1162/Fax: +81-5-7523-1719
e-Mail: info@nbk1560.com

Contact (Europe)

Zimmer Group
Im Salmenkopf 5 77866 Rheinau - Germany
+49 78 44 9139-0
e-Mail: info@zimmer-group.de

Contact (China)

ZIMMER GROUP CHINA LTD.
Level 2-D3, Bldg 4, 526, Fu-Te East 3rd Rd.
CN 200131 Pudong, Shanghai
T +86 2161 630506
e-Mail: info.cn@zimmer-group.com

Contact (North America)

ZIMMER GROUP US INC.
1095 6th Street Ct SE
US 28602 Hickory, NC
T +1 828 855 9722
e-Mail: info.us@zimmer-group.com

This two-clawed parallel electric gripper is exclusively for collaborative robots and compliant with safety standard ISO/TS 15066. Its built-in controller and mechanical cell clock ensure that it will not drop workpieces it is holding, even in the event of a power outage.



Dedicated Model

Model HRC-03-099455
Weight 916g (including attachments and fingers)
Stroke 20mm (Single-claw stroke 10mm x 2)
Grip Force 50N, 90N, 140N, 190N (adjustable within 4 stages)

Gripper

GIMATIC Gimatic Japan Ltd.

As a gripper manufacturer, Gimatic offers a broad lineup of air and electric grippers, and can support the design, manufacture, and assembly of end effectors based on injection molded part extraction.

Contact (Japan)

11F TOC Bldg., 7-22-17 Nishi-Gotanda, Shinagawa-Ku, Tokyo 141-0031, Japan
Int'l: +81-3-6206-4235/Fax: +81-3-6800-2770
e-Mail: info.jp@gimatic.com

Contact (Europe)

Gimatic Srl
Via Enzo Ferrari 2/4 25030 Roncadelle (Bs) Italy
Tel: +39 030 2584655
e-Mail: info@gimatic.com

Contact (China)

GIMATIC AUTOMATION ENGINEERING (CHANGSHU) CO., LTD
ROOM 902, N. 333, SOUTHEAST AVENUE
CHANGSHU RC 215500
Phone: +86051252977396
e-Mail: info.cn@gimatic.com

Contact (North America)

GIMATIC USA - Ohio
28300 EUCLID AVE WICKLIFFE, OHIO USA 44092
Phone: +1 216 535 4811
Fax: +1 216 535 4833
e-Mail: sales@gimaticusa.com

This parallel open/close plug-and-play gripper has a built-in driver. Maintenance is not required for 10 million cycles. Its original mechanism means that it does not consume power while the jaw is stopped, and it maintains its gripped state even in case of a power outage.



Dedicated Model

Model KIT-ASSISTA-G
Weight 922g (including attachments)
Stroke 35mm (Single-claw stroke 17.5mm x 2)
Grip Force 98N

SCHMALZ Schmalz Inc.

Schmalz is a vacuum transport device manufacturer founded in 1910. From highly versatile suction-type robot hands to suction pads, and high-performance vacuum generators, the company provides customers with a wide range of products that meet the needs of each industry, as well as vacuum know-how cultivated on a global scale.

Contact (Japan)

3001-7 Odanacho, Tsuzuki-ku, Yokohama-shi, Kanagawa 224-0027, Japan
Int'l: +81-45-565-5150/Fax: +81-45-565-5151
e-Mail: info@schmalz.co.jp

Contact (Europe)

J. Schmalz GmbH
Johannes-Schmalz-Str.1 DE-72293 Glatten
Tel: +49 7443 2403-0
e-Mail: schmalz@schmalz.de

Contact (China)

Schmalz (Shanghai) Co. Ltd.
No. 1 Chunquan Road, CN-201210 Pudong Shanghai China
TEL: +86 21 5109 9933
Mail: schmalz@schmalz.net.cn
HP: http://www.schmalz.net.cn

Contact (North America)

Schmalz Inc.
5850 Oak Forest Drive, Raleigh, NC 27616 USA
TEL: +1 (919) 713-0880
Mail: schmalz@schmalz.us
HP: https://www.schmalz.com/en/

This is the industry's most compact, lightweight electric vacuum pump. It achieves vacuum transport without using air or a hose. Its smart body also makes it perfect for bin picking.



Dedicated Model

Model ROB-SET ECBPM ASSISTA
Weight 580g (includes hand bracket)
Flow volume 1.6L/min
Grip Force -60kPa (vacuum max. pressure)

SMC SMC Corporation

SMC was founded in 1959 as a general manufacturer of pneumatic devices. It currently manufactures and sells automatic control equipment. Support is provided via 54 domestic sales branches and 560 sales branches in 83 countries and regions.

Model JMHZ2-16D-X7400B-ASSISTA
Weight 581g (includes product attachment bolts and straight pins)
Stroke 10mm (Single-claw stroke 5mm x 2)
Grip Force 32.5N (at outer diameter grip/0.5MPa)
43.5N (at inner diameter grip/0.5MPa)

Contact (Japan)

15F Akihabara UDX, 4-14-1 Soto-Kanda, Chiyoda-ku, Tokyo 101-0021, Japan
Int'l: +81-3-5207-8271/Fax: +81-3-5298-5361
e-Mail: yokota.akinori@smcjp.com

Based on the concept of "plug-and-play that can be used right away," it is equipped with an ISO9409-1-compliant robot brush and can be simply attached without requiring the manufacturing of attachments. Electrical cabling is connected simply using one connector and it can operate using just one air pipe.



Dedicated Model

Gripper

CONVUM Convum Mytoku Ltd.

Device that act as robot hands are available. The fully standardized CRK Series includes brush, arm, and suction pad. No design work is required and delivery can be completed in a short period of time. Please contact us to discuss our suction hands.

onrobot OnRobot Japan

Capable of connecting to various types of robots from each company via a shared mount-type quick changer. Plans are to increase the quantity of products to 40 beginning in 2020.

THK INTECHS THK Intechs

THK Intechs, through its experience with various types of collaborative robot engineering, has developed several convenient options for utilizing collaborative robots. Selecting these superior options will create unimaginable performance benefits. This will not only increase work efficiency, but also further increase the versatility of your collaborative robots.

Model N-HD-ASSISTA-NAIL-SET
Support hand GIMATIC "KIT-ASSISTA-G" proprietary

Contact (Japan)

2-12-10 Shibaura, Minato-Ku, Tokyo 108-0023, Japan
Int'l: +81-3-5730-3814 (direct line to Robot Dept.)/
FAX: +81-3-5730-3815
e-Mail: robot@thkintechs.co.jp

Contact

502, Meiekiminami Bldg. No. 2, 4-8-17 Meiekiminami, Nakamura-ku, Nagoya City, Aichi Prefecture, 450-0003, Japan
Int'l: +81-52-533-9120
e-Mail: yukinori-hibino@convum.co.jp
Regions supported: Japan, Europe, China, North America, ASEAN, other overseas locations

Contact

45F Sunshine 60 Bldg., 3-1-1 Higashi-Ikebukuro, Toshima-ku, Tokyo 170-6045, Japan
Int'l: +81-3-5957-3794
e-Mail: takashi.suzuki@onrobot.com
Regions supported: Japan, Europe, China, North America, ASEAN, other overseas locations

Finger

THK INTECHS THK Intechs

THK Intechs, through its experience with various types of collaborative robot engineering, has developed several convenient options for utilizing collaborative robots. Selecting these superior options will create unimaginable performance benefits. This will not only increase work efficiency, but also further increase the versatility of your collaborative robots.

Model N-HD-ASSISTA-NAIL-SET
Support hand GIMATIC "KIT-ASSISTA-G" proprietary

Contact (Japan)

2-12-10 Shibaura, Minato-Ku, Tokyo 108-0023, Japan
Int'l: +81-3-5730-3814 (direct line to Robot Dept.)/
FAX: +81-3-5730-3815
e-Mail: robot@thkintechs.co.jp

- Package containing eight types of pins/connectors that can be used to mount the GIMATIC "KIT-ASSISTA-G".
- Capable of supporting a variety of workpiece shapes by changing combinations
- Supports both grip and suction
- Secures mounting reproducibility via position-determining mechanism

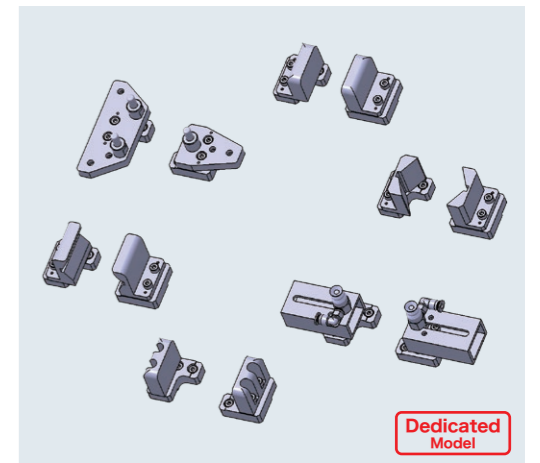

Dedicated Model

yasojima Yasojima Proceed Co., Ltd.

Proposes a robot hand that can fully utilize the characteristics of 3D printers. Achieves consistency from design to manufacturing.

Contact

5F, IT Meiki Bldg., 3-11-22 Meiki, Nakamura-ku, Nagoya City 450-0002, Japan
Int'l: +81-52-533-6130
e-Mail: usui@yasojima.co.jp
Regions supported: Japan

Sensor

THK INTECHS THK Intechs

THK Intechs, through its experience with various types of collaborative robot engineering, has developed several convenient options for utilizing collaborative robots. Selecting these superior options enables the realization of unimaginable performance benefits. This will not only increase work efficiency, but also further increase the versatility of your collaborative robots.

Model N-HD-SAF-ASSISTA-C
Weight 987g (Hand not included)
Stroke Compliance stroke 40mm
Portable mass Maximum 3Kg (weight of hands, fingers, etc.)

Contact (Japan)

2-12-10 Shibaura, Minato-Ku, Tokyo 108-0023, Japan
Int'l: +81-3-5730-3814 (direct line to Robot Dept.)/
FAX: +81-3-5730-3815
e-Mail: robot@thkintechs.co.jp

- By attaching this to a robot, it is possible to detect touch from the top and bottom clamping directions and mechanically protect robot and hand parts, peripheral devices, and body parts.
- Consideration is given to safety, with a built-in high-rigidity LM guide and SICK safety sensor.

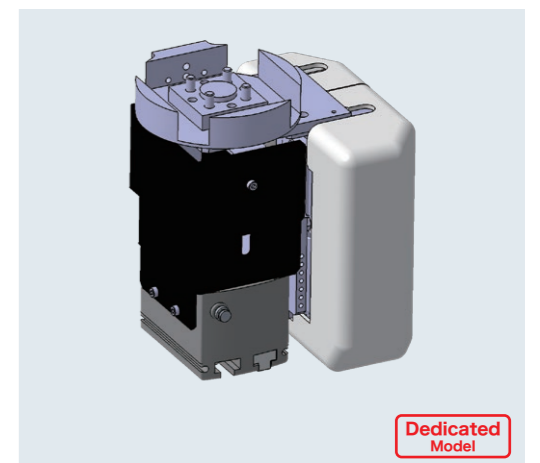

Dedicated Model

Sensor



Since its foundation, IDEC has been engaged in manufacturing that prioritizes the safety of people and machinery, and focuses on reliability and ease of use. Even in environments where cooperation is required, we provide safety and security that goes that one step further.

Contact

2-6-64 Nishimiyahara, Yodogawa-ku, Osaka
City 532-0004, Japan
Int'l: +81-6-6398-2571
e-Mail: s.mitsugochi@jp.idec.com
Regions supported: Japan, Europe, China,
North America, ASEAN, other overseas
locations



Providing solutions that enable collaborative robots to be used more efficiently.
① A safety laser scanner that can be used in a wide variety of environments
② A safety controller that can be used intuitively with limited wiring
③ Safety services such as providing risk assessments and sample programs

Contact

13F, Harmony Tower, 1-32-2 Honmachi, Nakano-Ku, Tokyo
164-0012, Japan
Int'l: +81-3-5309-2112
Regions supported: Japan, Europe, China, North America,
ASEAN, other overseas locations



Igus was founded in 1964, and its service network now extends to 72 countries throughout the world, including its head office in Germany. Based on its resin material development, molds, and molding technologies, with reliable technologies accumulated through experience, and achieving an impressive track record, the company strives to improve the mechanical performance and productivity of its customers throughout the world, doing so by aiming for plastics with longer service life (↑ extended lifetime with lower costs).

Model Name TRE30-ASSISTA-S
TRE30-ASSISTA-KL

Contact (Japan)

15F, ARCA Centre, 1-2-1 Kinshicho, Sumida-ku, Tokyo 130-0013, Japan
Int'l: +81-3-5819-2500/Fax: +81-3-5819-2055
e-Mail: helpdesk@igus.co.jp

"Triflex R" multi-jointed cable protection tubes can be affixed on the robot arm section simply by hand, without requiring the use of any tools, enabling power to be provided smoothly to movable parts.

Type using wiring from the upper section of the arm (short type)

● TRE30-ASSISTA-S
TRE.30.050.0-75links
TR.CO8.01.30.21.0 1 item (surface fastener 1m)
TR.CO8.01.30.20.0 1 item (surface fastener 1m)

Type using wiring from the base (long type)

● TRE30-ASSISTA-L
TRE.30.050.0-150links
TR.CO8.01.30.21.0 1 item (surface fastener 1m)
TR.CO8.01.30.20.0 2 items (surface fastener 1m)



Dedicated Model



Murrplastik Head Office: Baden-Württemberg, Germany
<https://www.murrplastik.de/>
This global company provides resilient cable protection and management systems, that can be mounted easily, such as cable drag chains, robot cable protective tubing, cable label rings, wire-saving cable entry systems, etc.

Model Name FHS-C-Set ASSISTA-RV5
FHS-UHE-Set ASSISTA-RV5
FHS-SH-Set AS

Contact (Japan)

7F, Yoshiyasu Kanda Bldg., 2-1-15 Iwamotocho, Chiyoda-ku, Tokyo 101-0032, Japan
Int'l: +81-3-3864-0888/Fax: +81-3-3864-0881
e-Mail: s.masuda@kmeecs.co.jp

This set protects the external cabling of collaborative robots. It is also simple to mount the harnessed cables.

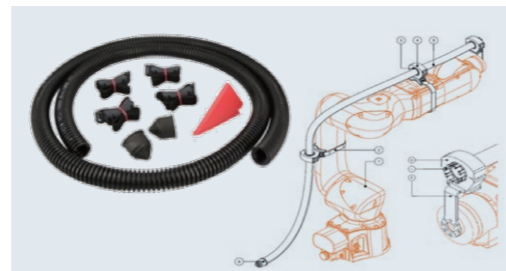

Dedicated Model



A trading company for control/FA machinery. In addition to robot carts, automation and factory IoT solutions are offered. Please also inquire regarding interest in automating facilities.

Model HC-1-ASSISTA
Size W600×D780×H910
Weight 240kg

Contact (Japan)

1-14-10 Shiba, Minato-ku, Tokyo 105-0014, Japan
Int'l: +81-3-3452-7161/Fax: +81-3-3798-2475
e-Mail: zhk-fasolution-sales@satori.co.jp

Movement is simple owing to the compact, square form. This is a convenient cart exclusively for use with the MELFA ASSISTA, which enables affixing the foot pedal and immediately starting work.



Dedicated Model

Hand Cart



NIC, Autotec, Inc.

This device manufacturer uses originally developed industrial aluminum structural materials. By being the first in the world to create a numerical basis for frame rigidity values, aluminum robot frames have been standardized. Based on abundant performance data focusing on robot frames, the company proposes ideal frames to meet customers' needs.

Model AK-R-ASSISTA
Size W600×D900×H900
Weight 95kg

Contact (Japan)

11F, B Block, Ariake Frontier Bldg., 3-7-26 Ariake, Koto-ku, Tokyo 135-0063, Japan
Int'l: +81-3-5530-8060/Fax: +81-3-5530-8070
e-Mail: tokyo@nic-inc.co.jp

This is a dedicated ASSISTA frame for connecting controllers only and equipped with standard 24VDC power. In addition to the controller, it is possible to install peripheral devices and PLC units within the frame.



Dedicated Model

AGV/AMR



Tanabe Engineering Corporation

Single-handed support of all processes, from design to manufacturing, for various automated machinery. Capable of proposing peripheral equipment based on AGV customization where necessary.

Model WYN700-MR-ASSISTA
Size W558 x D688 x H1000 (including bumper)
*Reference values for AGV main body excluding robot
Weight Approx. 260kg
*Reference values for AGV main body excluding robot

Contact (Japan)

7F, Koshin Bldg., 1-10 Kandaogawamachi, Chiyoda-ku, Tokyo 101-0052, Japan
Int'l: +81-3-5207-7140
e-Mail: webothers@tanabe-ind.co.jp

Utilizing guideless travel with a range sensor (laser range), guide laying construction is completely unnecessary on deployment. Additionally, not only the AGV main body, but also the safety sensors for robots, etc. can be customized to match a user's safety standards.



Dedicated Model

Software



Utilizing its multi-view camera, this tool can be easily configured whenever, wherever necessary. It supports increasing production by enabling the simple checking of events such as the cause of equipment stoppage and tact fluctuation.

Contact

1005 Shimogino, Atsugi, Kanagawa Prefecture, 243-0298, Japan
<https://industry.ricoh.com/alr/>

All Line Recognizer
ALR V2

Safety Fence



Owing to the simple modular format, assembly of this safety fence is both quick and safe. Using only the dedicated X-KEY, the lightweight, easy-to-handle nature of the panel enables it to be assembled by one person.

Contact

Captain Building, 4-8-8 Funabori, Edogawa-Ku, Tokyo 134-0091, Japan
Int'l: +81-3-5674-1611
Regions supported: Japan, Europe



Screw



This ultralightweight, compact electric driver can be attached to a robot using only two screws when integrated with HIOS' PAT. screws (TOTUPLA screw/INTRTORQUE), thereby fully supporting the deployment of automation.

Contact

1-35-1 Oshiage, Sumida-ku, Tokyo 131-0045, Japan
Int'l: +81-3-6661-8777/Fax: +81-3-6657-0888
e-Mail: jp_hp@hios.com
Regions supported: Japan

Cable Guide

Hand Cart

Robot arm

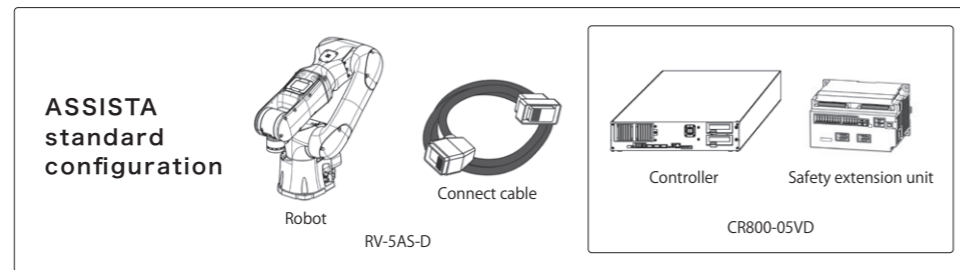

Standard specifications of RV-5AS-D robot

Item	Unit	Specifications	
IP Rate		IP54	
Degree of freedom		6	
Installation posture		Floor mounted / ceiling mounted	
Structure		Vertical, multiple-joint type	
Operating range	Degree	Waist (J1)	±240
		Shoulder (J2)	±148
		Elbow (J3)	±150
		Wrist twist (J4)	±200
		Wrist pitch (J5)	±120
		Wrist roll (J6)	±200
Speed of motion ^{Note1)}	Degree/s	Waist (J1)	124 (59.6)
		Shoulder (J2)	124 (34.0)
		Elbow (J3)	124 (34.0)
		Wrist twist (J4)	297 (142)
		Wrist pitch (J5)	356 (215)
		Wrist roll (J6)	360
Maximum reach radius	mm	910	
	Maximum resultant velocity ^{Note2)}	High-speed operation mode	1,000
Collaborative operation mode (Standard operation)		250	
Collaborative operation mode (Low-speed operation)		50	
Load	Rating	5	
	Maximum ^{Note3)}	5.5	
Pose repeatability	mm	±0.03	
Ambient temperature ^{Note4)}	°C	0 to 40	
Mass	kg	32	
Wiring	Hand I/O	-	Mechanical interface: 2 inputs/4 outputs Forearm: 6 inputs/0 outputs Base: 0 inputs/4 outputs
	Force sensor cable/Spare cable	-	5-conductor (24 V/0.7 A) One of the conductors should be used for the frame ground (FG).
	LAN cable	-	Cat-5e supported
Plumbing	Primary hoses	-	Φ6 × 2
	Secondary hoses	-	Φ4 × 4 From the base of the robot to the elbow.
Supply pressure	MPa	0.54	

Note1) Values in parentheses indicate the maximum speed when the input voltage is single-phase 100 to 120 VAC.

Note2) These values represent the maximum overall speed of all axes combined. The safety functions limit the robot to the speeds shown in the table. For accurate collision force data when the robot is in Collaborative operation mode, measure collision forces under actual operating conditions.

Note3) Allowable load when the mechanical interface faces downward at an inclination within ±10° to the vertical direction.

Note4) Sets the robot's operating environmental temperature as parameter OLTMX. The initial value is 30 (°C). Corresponding to the environment, the continuous control action performance and the overload-protection function are optimized.

Outside dimension

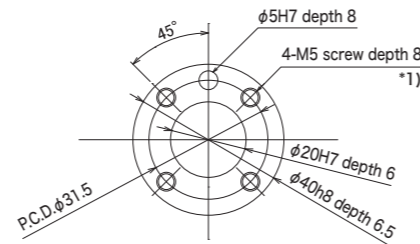
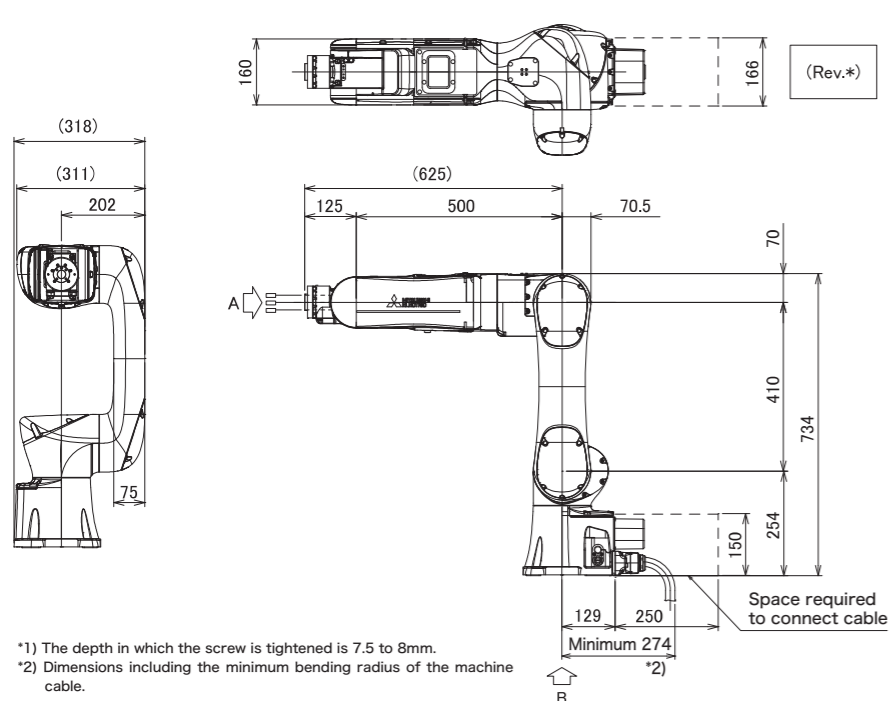

View A: Detail of mechanical interface

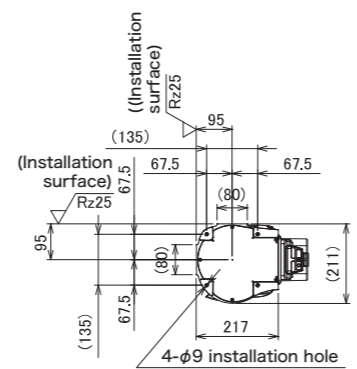

View B: Detailed installation dimensions

*1) The depth in which the screw is tightened is 7.5 to 8mm.

*2) Dimensions including the minimum bending radius of the machine cable.

CR800-05VD controller specifications of controller

Item	Unit	Specification	Remarks	
Number of control axis	-	Simultaneously 6	-	
Memory capacity	Programmed positions	point	39,000	Number of program blocks when using RT VisualBox: 2000 (vision sensor not used), 1800 (vision sensor used) Number of programs: 505 (vision sensor not used), less than 500 (vision sensor used) ^{Note1)}
	No. of steps	step	78,000	
	Number of program	-	512	
Robot language	-	MELFA-BASIC VI	-	
Teaching method	-	Pose teaching method, MDI method	-	
External input and output	Input/output	point	0/0	Max. 64/64 by option
	Dedicated input/output	-	Assigned with general-purpose input/output	The signal number of "STOP" input signals is fixing.
	Emergency stop input ^{Note2)}	point	1 (duplicated)	
	Emergency stop output	point	1 (duplicated)	
	Mode selector switch input ^{Note3)}	point	1 (duplicated)	
	Mode output	point	1 (duplicated)	
	Robot error output	point	1 (duplicated)	
Door switch input	point	1 (duplicated)		
Encoder input	Channel	2	-	
Safety I/O	point	8 (duplicated) / 4 (duplicated)	Safety extension unit	
	Force sensor interface	Channel	1	-
Interface	Remote input/output	Channel	1	For connection to the Safety extension unit.
	USB	port	1	Ver. 2.0 High-Speed device functions only, USB mini-B
	Ethernet	port	1	For customer: 100BASE-T/100BASE-TX/10BASE-T
		port	1	Dedicated T/B port: 100BASE-TX/10BASE-T
	Option slot	slot	2	For option interface
	SD memory card slot	slot	1	For extended memory
	RS-422	port	1	Dedicated T/B port
Power source	Input voltage rang	V	Single phase AC 100 to 120 Single phase AC 200 to 230	The rate of power-supply voltage fluctuation is within 10%.
	Power capacity	kVA	1.0	Does not include rush current. ^{Note4)}
	Power supply frequency	Hz	50/60	-
Outline dimensions	mm	430(W) × 425(D) × 99.5(H)	Excluding protrusions	
Mass	kg	Approx.12.5	-	
IP Rate		IP20	-	
Ambient temperature	°C	0 to 40	Without freeze	
Ambient humidity	%RH	45 to 85	Without dew drops	
Grounding	Ω	100 or less	Class D Grounding ^{Note5)}	

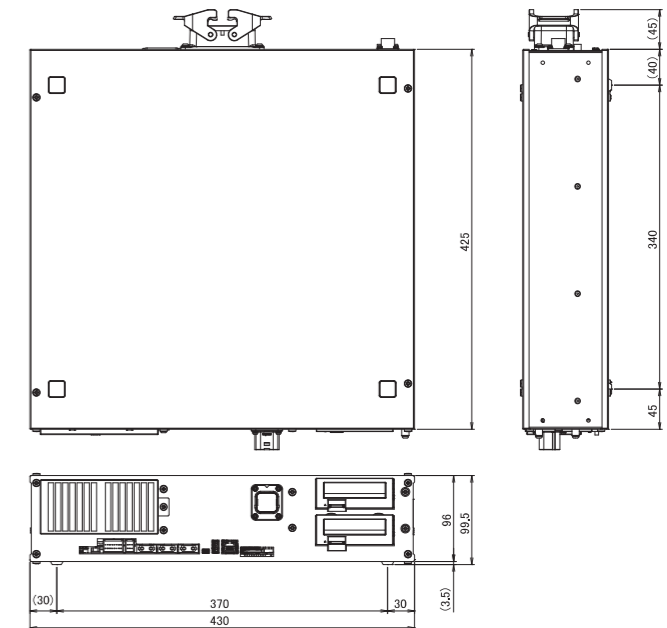

Note1) The maximum number of usable programs differs depending on the number of types of workpieces that are registered.

Note2) Only the STO function can meet the requirements of Category 4, Performance Level e. At factory settings, the STO function meets the requirements of Category 3, Performance Level d. To make the STO function meet the requirements of Category 4, Performance Level e, change the parameter setting.

Note3) Provide a mode selector switch to change the mode (MANUAL/AUTOMATIC) of the controller.

Note4) The power capacity is the recommended value. The power capacity does not include the rush current when the power is turned ON. The power capacity is a guideline and the actual operation is affected by the input power voltage.

Note5) The robot must be grounded by the customer.

Safety extension unit

Item	Description	Remarks	
Safety function	STO function	The function electrically shuts off the driving energy to the motor of the robot arm. IEC 60204-1 Corresponds to stop category 0	
	SS1 function	The function to control and decelerate the motor speeds of the robot. After stopping, the robot transitions to the STO state. IEC 60204-1 Corresponds to stop category 1	
	SS2 function	The function to control and decelerate the motor speeds of the robot. After stopping, the robot transitions to the SOS state. IEC 60204-1 Corresponds to stop category 2	
	SOS function	Without shutting off the driving energy to the motors, this function monitors the robot so that it stays at rest.	
	SLS function	This is a function to monitor each part of the robot arm so that their speeds do not exceed monitoring speeds. When SOS, SLS, SLP, and STR detect error, activate SS1. EN 61800-5-2 compliant	
	SLP function	The function monitors specified monitoring positions so that they do not go across position monitoring planes.	
	STR function	This function ensures that the torque limits of each motor in the robot are not exceeded.	
Standard		EN ISO 10218-1: 2011 ISO/TS 15066: 2016 EN ISO 13849-1: 2015 IEC 61800-5-1: 2007 EN 61800-5-2: 2017 EN 61000-6-2: 2015 EN 61326-3-1: 2017 IEC 61508-1: 2010 IEC 61508-2: 2010 IEC 61508-3: 2010 EN 62061: 2005/AMD1: 2012/AMD2: 2015 IEC 62061: 2005/AMD1: 2012/AMD2: 2015	
Safety performance	Performance	STO SIL2, PLd/Category 3 (at factory settings) SIL3, PLe/Category 4 (with changes to parameters)	
	Dangerous failure rate	SS1, SOS, SS2, SLS, SLP, STR SIL 2, PLd/Category 3	
Safety extension unit	Power supply specifications	Voltage: 24 V DC ± 5% Ripple 0.2 V (P-P) Maximum consumption current: 300 mA	
	IP Rate	IP20	
	Weight	0.8kg	
	Environment	Operating temperature range	0 to 40°C It must be kept away from heat appliances and other heat sources.
		Relative humidity	45 to 75% Without dew drop
	Input signal	8 routes (duplicated signal)	
Output signal	4 routes (duplicated signal)		

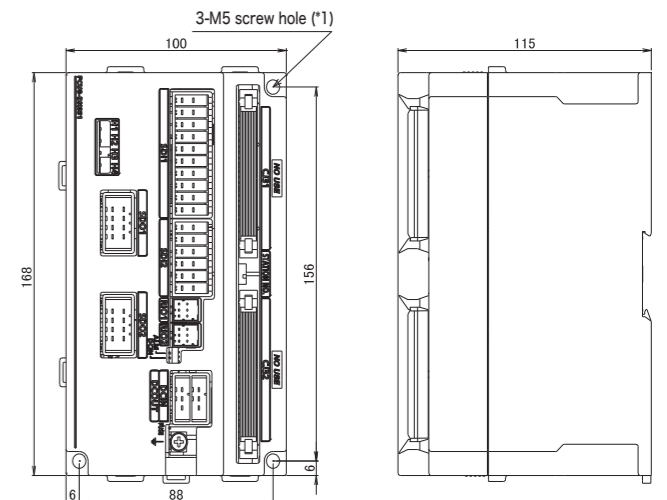

The list of robot option equipment

Item	Type	Description
Machine cable (replacement)	1F-□□UCBL-41	"□□" in type shows the length of the cables as follows. 02=2 m, 10=10 m (Changed from the original length of 5 m)
Solenoid valve set	1F-VD0□-01(Sink)	Sets with one or two valves are available. Φ4 diameter output hoses The number that replaces "□" indicates the number of valves the solenoid has (1 or 2).
	1F-VD0□E-01(Source)	
2-piece force sensor conversion cable set	1F-ASSISTA-ADCBL	2-piece force sensor conversion cable set (hand cable/base cable) required to connect the force sensor to the robot.
Vision sensor mounting bracket	1F-ASSISTA-2DVSFLG	Bracket required to connect a vision sensor to the hand.

The list of the controller option equipment and special specification

Item	Type	Description
Easy-setup kit	4F-ASSISTASETUP-JP (for Europe/China)	A kit which aids setup that consists of switches, a connector cable, and a 24 V power supply.
	4F-ASSISTASETUP-EU (for Japan/NorthAmerica)	
RT VisualBox	3G-30C-WINE	Windows 10 Supporting English.
RT ToolBox3	3F-14C-WINE	Windows 7, Windows 8, Windows 8.1, Windows 10 Supporting English. (With the simulation function) Ver.1.70Y or later
RT ToolBox3 mini	3F-15C-WINE	Windows 7, Windows 8, Windows 8.1, Windows 10 Supporting English. Ver.1.70Y or later
Simple teaching pendant	R32TB/R32TB-15	Cable length 7m, Cable length 15m
Highly efficient teaching pendant	R56TB/R56TB-15	Cable length 7m, Cable length 15m
Parallel I/O Interface	2D-TZ368(Sink type)	DO: 32 point
	2D-TZ378(Source type)	DI: 32 point
External I/O cable (For Parallel I/O Interface)	2D-CBL05	CBL05:5m, CBL15:15m Use to connect the external peripheral device to the parallel input/output interface.
CC-Link interface	*1 2D-TZ576	Only intelligent device station, Local station.
Network base card (EtherNet/IP interface)	*1 2D-TZ535	Communication interface for mounting the Anybus CompactCom module manufactured by HMS. The customer needs to prepare the EtherNet/IP module (AB6314) manufactured by HMS.
Network base card (PROFINET interface)	*1 2D-TZ535-PN	Communication interface for mounting the Anybus CompactCom module manufactured by HMS. The customer needs to prepare the PROFINET IO module (AB6489-B) manufactured by HMS.
Network base card (CC-Link IE Field interface)	*1 2F-DQ535	Communication interface for mounting the Anybus CompactCom module manufactured by HMS. The customer needs to prepare the CC-Link IE Field module (AB6709) manufactured by HMS.
Network base card (EtherCAT interface)	*1 2F-DQ535-EC	Communication interface for mounting the Anybus CompactCom module manufactured by HMS. The customer needs to prepare the EtherCAT module (AB6607) manufactured by HMS.
SD memory card	*1 2F-2GBSD	Memory card capacity 2GB.

*1 Not supported by RT VisualBox.

The list of function extension device

Item	Type name	Specifications
Force sensor set	*1 4F-FS002H-W200	A set of devices necessary for force sense control function, such as a force sensor, an interface unit, and support software.

*1 Not supported by RT VisualBox.

ASSISTA Startup Configuration

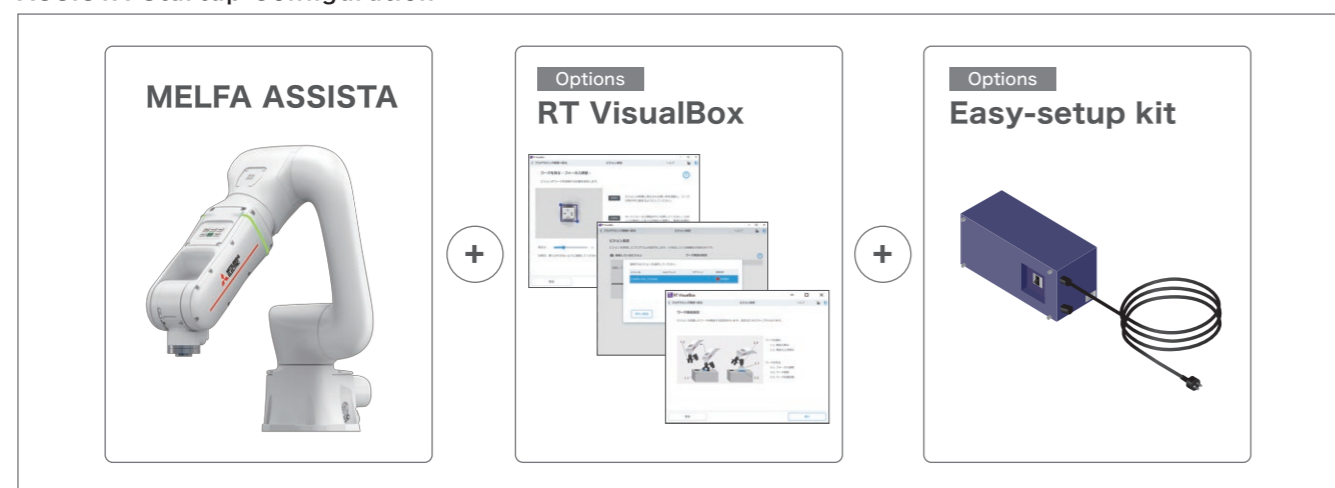

YOUR SOLUTION PARTNER

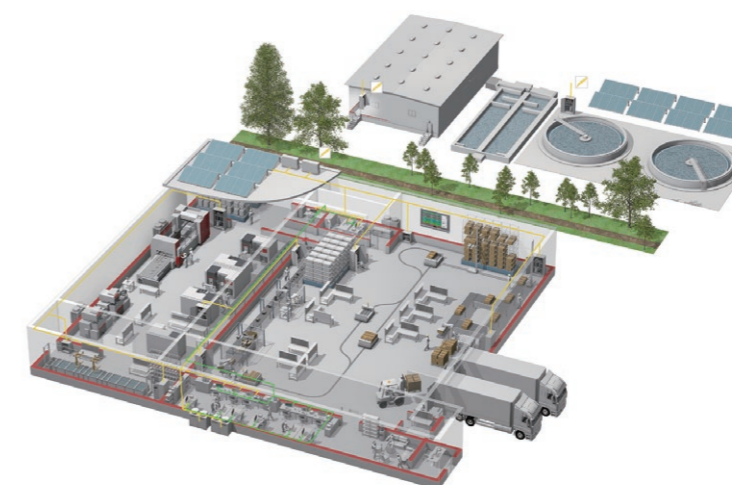

Mitsubishi Electric offers a wide range of automation equipment from PLCs and HMIs to CNC and EDM machines.

A NAME TO TRUST

Since its beginnings in 1870, some 45 companies use the Mitsubishi name, covering a spectrum of finance, commerce and industry.

The Mitsubishi brand name is recognized around the world as a symbol of premium quality.

Mitsubishi Electric Corporation is active in space development, transportation, semi-conductors, energy systems, communications and information processing, audio visual equipment and home electronics, building and energy management and automation systems, and has 237 factories and laboratories worldwide in over 121 countries.

This is why you can rely on Mitsubishi Electric automation solution - because we know first hand about the need for reliable, efficient, easy-to-use automation and control in our own factories.

As one of the world's leading companies with a global turnover of over 4 trillion Yen (over \$40 billion), employing over 100,000 people, Mitsubishi Electric has the resource and the commitment to deliver the ultimate in service and support as well as the best products.



Low voltage: MCCB, MCB, ACB



Medium voltage: VCB, VCC



Power monitoring, energy management



Compact and Modular Controllers



Inverters, Servos and Motors



Visualisation: HMIs



Numerical Control (NC)



Robots: SCARA, Articulated arm



Processing machines: EDM, Lasers, IDS



Transformers, Air conditioning, Photovoltaic systems

* Not all products are available in all countries.