

# PACKAGING AUTOMATION SOLUTIONS

Sharpen your edge with programmable & motion controllers



## **Packaging Solutions:**

- Filling
- Vertical Form Fill Seal (VFFS)
- Horizontal Form Fill Seal (HFFS)
- Labeling
- Case Packing
- Bagging
- Palletizing

IT'S IN THE BAG

# ENTERPRISE TO DEVICE-LEVEL CONTROL SOLUTIONS



## INNOVATION AND EXPERTISE

Mitsubishi Electric is a global supplier of automation and software solutions for a wide range of industries and markets. For decades, we have been working with end users and OEMs in the packaging sector to address everyday issues that occur in filling, labeling, and bagging applications, to name a few.

We can help you evaluate your business challenges and provide innovative ideas to reduce costs, improve productivity, and maintain quality and consistency within your operation.

Mitsubishi Electric leverages expertise from our own manufacturing processes to develop affordable, quality automation solutions for your supply chain.

- PLC
- Robots
- HMIs
- VFDs
- Servos
- Motion Controllers
- ICONICS SCADA

All designed to identify and report nonconformance, downtime, and productivity rates.

## BRIDGING THE IT/OT GAP

Our MELSEC iQ-R automation platform integrates Operational Technology such as general, process, and motion control on a Information Technology capable network. Mitsubishi Electric's CC-Link IE TSN protocol uses time-sensitive networking to connect you to everything you need for smart packaging machine systems.

- Motion controllers and PLCs are integrated on the same base for highly accurate, high-speed solutions.
- PackML compliance makes it easy to interface machine cycles and functions from multiple OEMs.
- Our extensive library of PLCopen function blocks increases efficiency and reduces costs.
- iQ-R's full range of digital, analog, and intelligent I/O can further enhance and specify your application.

## PACKAGING AUTOMATION

Whatever your need, MELSEC Series PLCs have a solution to fit.

- iQ-F series for simple, low-cost advantages
- iQ-R series for high-speed registration with multiple axes
- CC-Link IE TSN for high-speed positional control

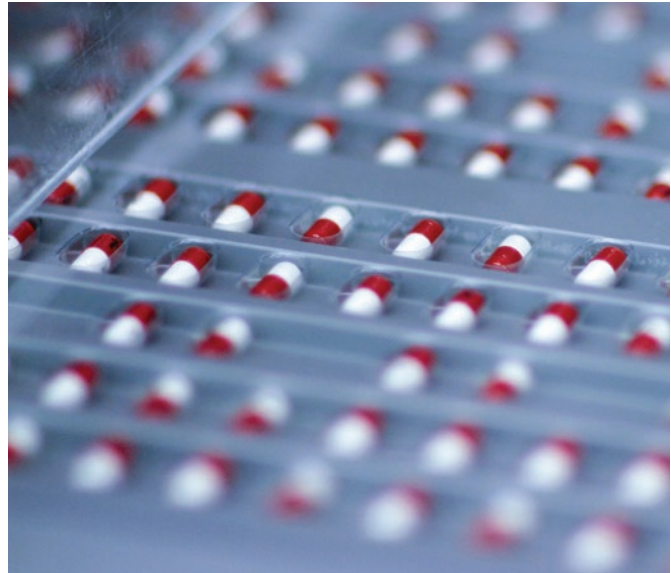

Welcome to Mitsubishi  
Electric's packaging world.  
Sharpen your edge with high-  
speed packaging solutions.



TRUE FULFILLMENT

# BOTTLE FILLING



## AN EASY POUR

Transporting liquid products into solid vessels is a complex application. It takes a highly capable function controller to maintain the speed and accuracy needed to convey the containers, insert the filling nozzle, and control the flow rate of the product. Mitsubishi Electric resolves these issues, simply and cost effectively.

- Ultrasonic level sensors
- Flow meters
- Bar codes
- Load cells/weigh scales

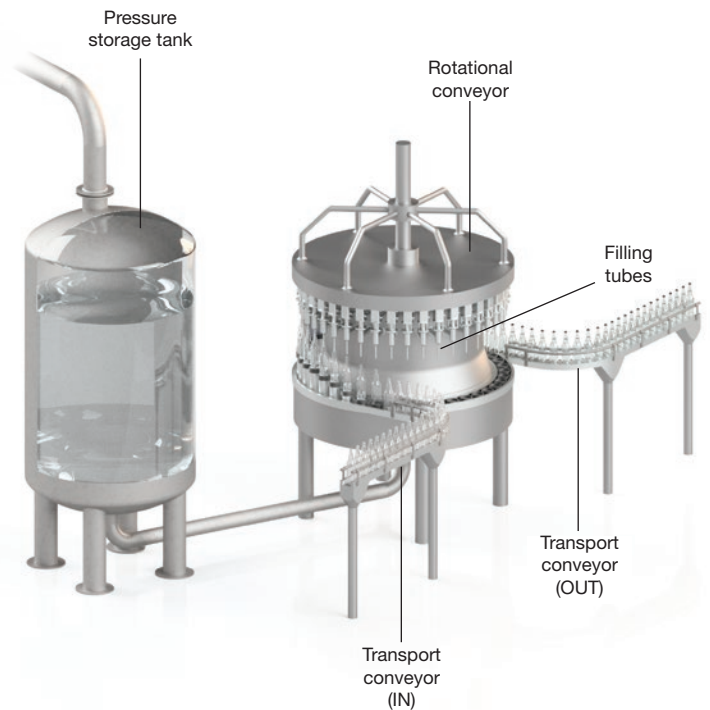

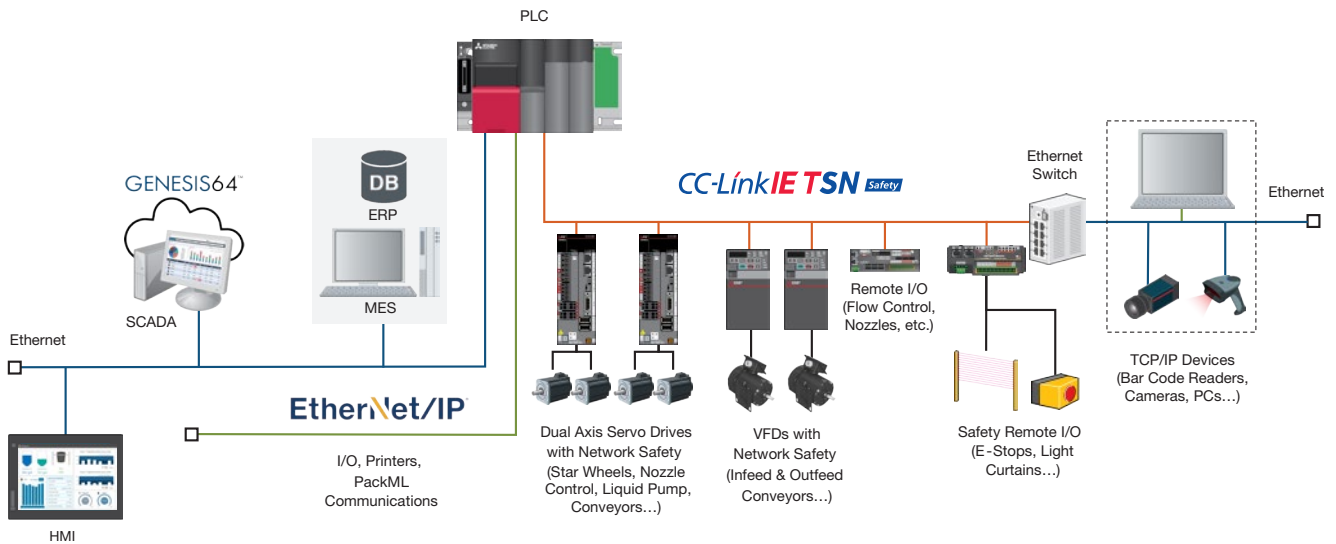

## ELECTRONIC CAMMING

The challenge for most bottle filling applications is to synchronize the filling nozzle with the rotational conveyor and flow controller to accurately feed the liquid into the bottle opening. Precise control of flow rate and nozzle height is also required to prevent frothing and overflow.



Mitsubishi Electric's iQ-R motion controller intelligently controls cam profiles. Our flexible software system replaces hardware-based methods, which are prone to deviation and error. If the bottle type changes, you can simply exchange the software, even while the system is in motion.

## TIME-SENSITIVE NETWORKING

Mitsubishi Electric's energy saving drives control feeding rates via the open CC-Link IE TSN network, which is centralized on the iQ-R series controller. The network offers 1 Gbps bandwidth a minimum update rate of 32.5  $\mu$ s, and program speeds in milliseconds. That means you can carry IT and OT traffic on the same network, making it the most connected controller ever.

- Maximize productivity and reduce costs with one network.
- Minimize complexity of system changes and line integration.
- Achieve faster cycle times with high-speed, high-accuracy motion control.

The iQ-R series can also connect to upper-level systems via Ethernet to monitor and report performance in real time. Local and remote I/O modules enable iQ-R to control most system components. Cam profiles can be easily switched using the GOT2000 human-machine touchscreen, which adds a user-friendly interface to the operation.

STICK THE LANDING

# LABELING



## ACCURATE EVERY TIME

Today's high-speed Labeling machines must apply labels with minimum deviation to maintain uniform positioning and orientation. Labels have to be fed at a consistent rate to prevent stretching, warping, or tearing. They come in a host of sizes and can adhere in a number of ways.

The control architecture of the Labeling machine needs to support all these variances without disrupting productivity. That's no problem for Mitsubishi Electric.

- Mix time
- Energy consumption
- Time under vacuum
- And more

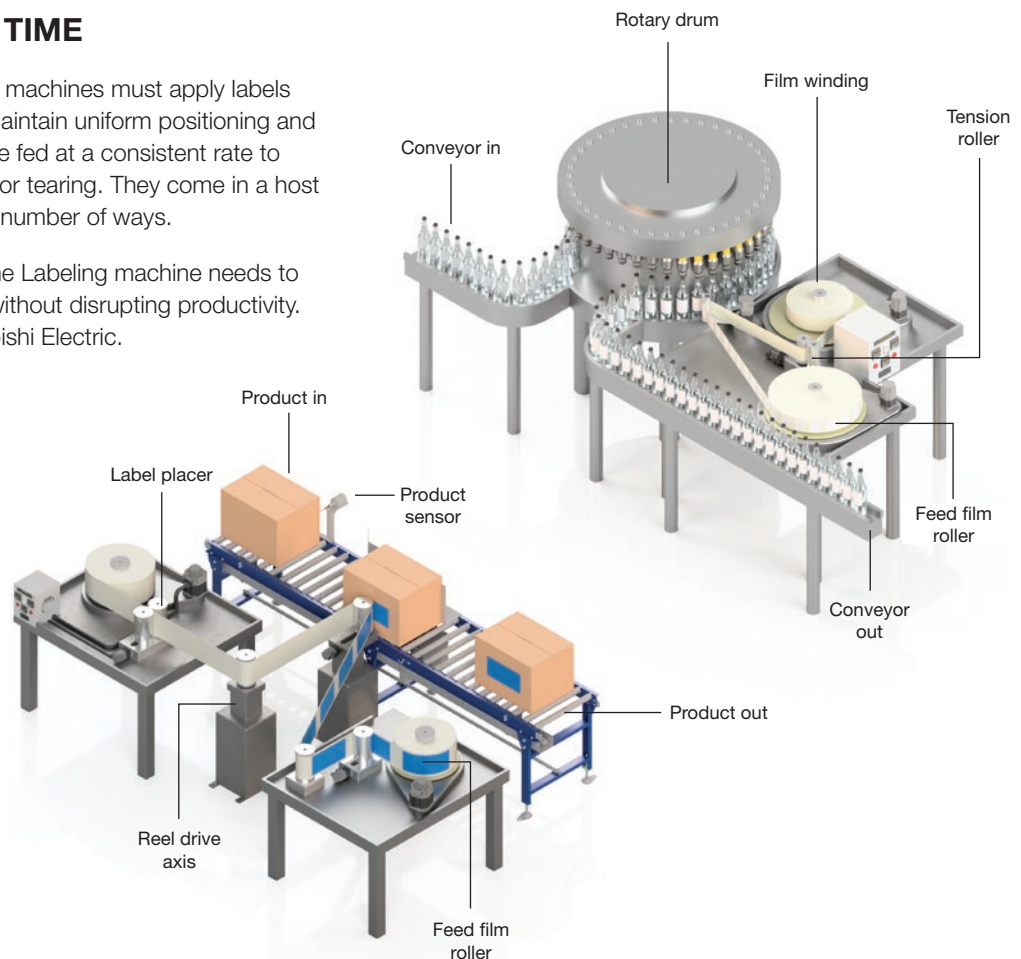

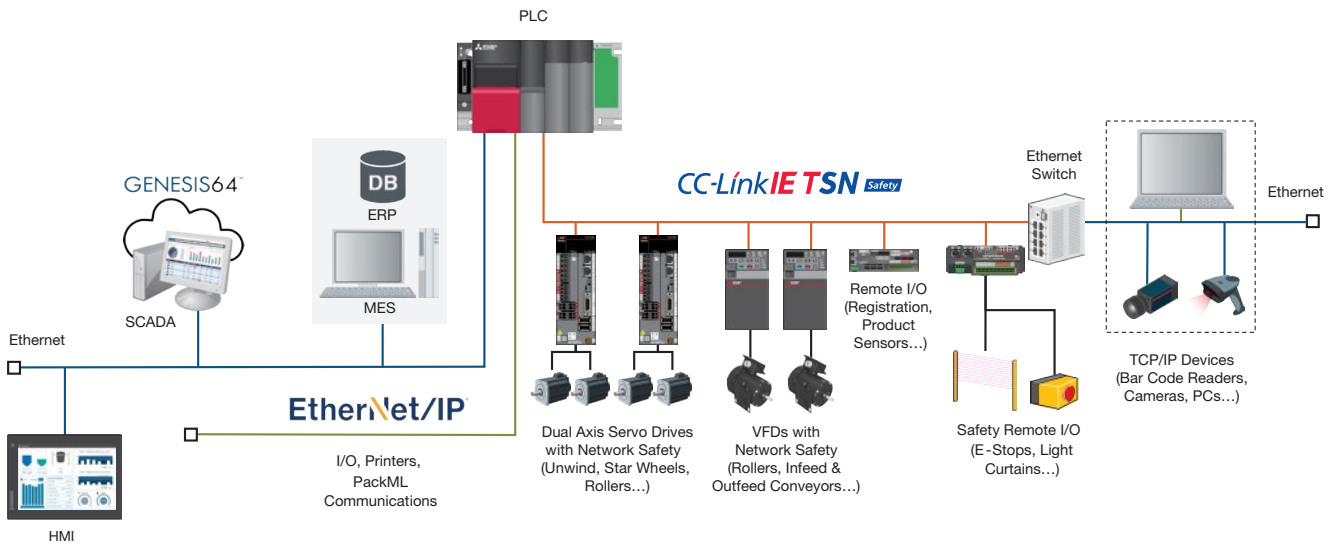

## HIGH-SPEED REGISTRATION

Our iQ-R series automation platform's high-speed registration functionality guarantees that label placement is always spot-on.

- The CPU logic controller easily controls the rotary drum, feed roller break, and bottle sensors with simple programming.
- Our GOT2000 high-resolution touchscreen allows real-time monitoring, debugging, and changes to parameter profiles.
- The MR-J5 series with CC-Link IE TSN provides high-speed servo control to ensure continuous label winding.
- The servo drive's patented auto-tuning function maintains film feed rates, even when the reel transfers from feed to winding rollers.



## SIMPLE INTEGRATION

In large-scale Labeling applications such as the robust box labeler, a simple setup is essential for hassle-free maintenance and reduced cost of ownership. A wide selection of iQ-F products is readily available for easy system integration, from intermittent-speed Labeling using conveyor belts to complex applications that require precise positioning and interpolation.

The iQ-F motion controller synchronizes multiple axes on the CC-Link IE TSN network for applications where timing is critical.

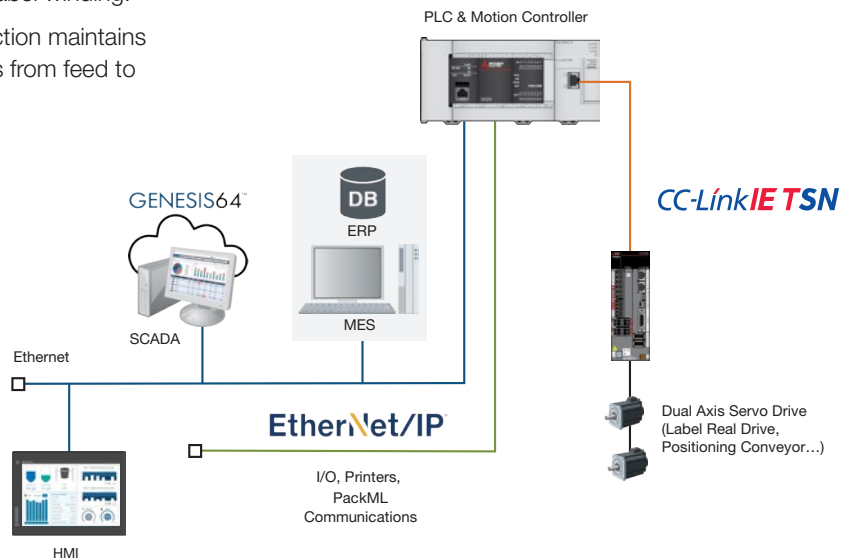

REST ASSURED

# HORIZONTAL/VERTICAL FORM FILL SEAL



## READY-MADE SOLUTIONS

Form fill seal-type packaging machines package anything from candy bars and pizzas to pharmaceutical and other non-food products. Packaging film is formed around the products, then sealed and cut to ready the individual items for shipping. The inline feed synchronizes with the film feed roller to move the film into the forming station.

This application requires the flexibility to cater to a diverse range of shapes and sizes. Mitsubishi Electric's iQ Monozukuri Packaging makes it easier to implement, bringing products to market faster and more efficiently.

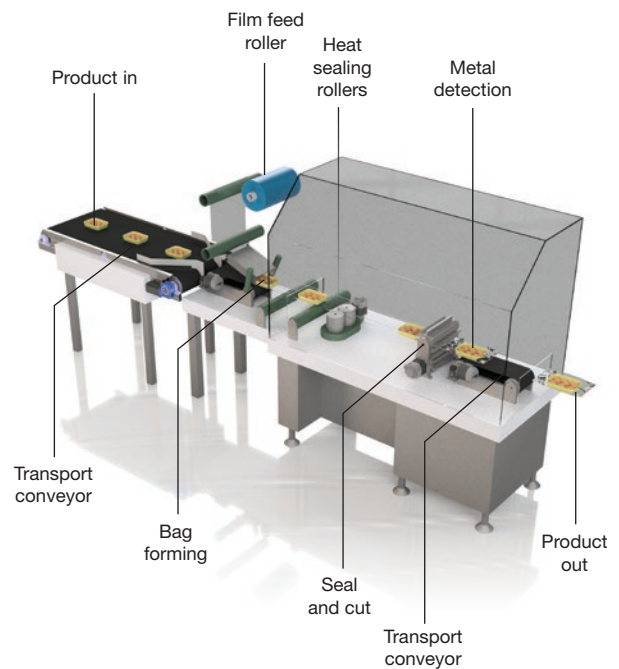



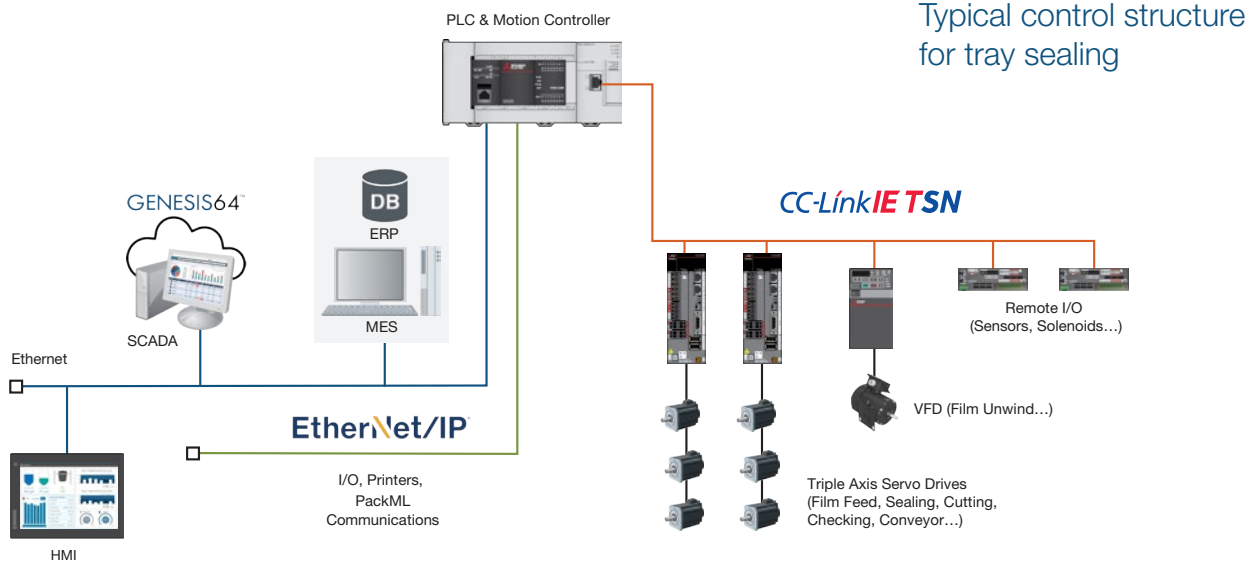

## PART AND PARCEL

iQ Monozukuri Packaging is a complete package of pre-engineered application solutions, including technical documentation, that is ideal for pillow-type machines.

- The MR-J5 series of servo drives allow high-speed performance.
- The iQ-F CC-Link IE TSN motion controller maintains accuracy.
- The iQ-F PLC makes programming simple.
- The GOT2000 provides an efficient user interface.

## PHASE COMPENSATION

The iQ-F CC-Link IE TSN motion controller incorporates a phase compensation algorithm to precisely synchronize encoder and cam phase angles for accurate cuts at high speeds.

## TENSION MAINTENANCE

Tension control reduces the chance of stretching, flapping, or warping packaging film as it enters the forming station. The iQ-F PLC's logic program continuously maintains film tension in real time.

## FEEDER FLEXIBILITY

Mitsubishi Electric's GOT2000 stores a diverse range of parameter profiles for specific processes. Real-time data can be uploaded to database servers via Ethernet. The iQ-F series monitors shop floor data to improve productivity and reduce downtime, which results in higher cycle counts and greater flexibility.



SHIP SHAPE

# CASE PACKING

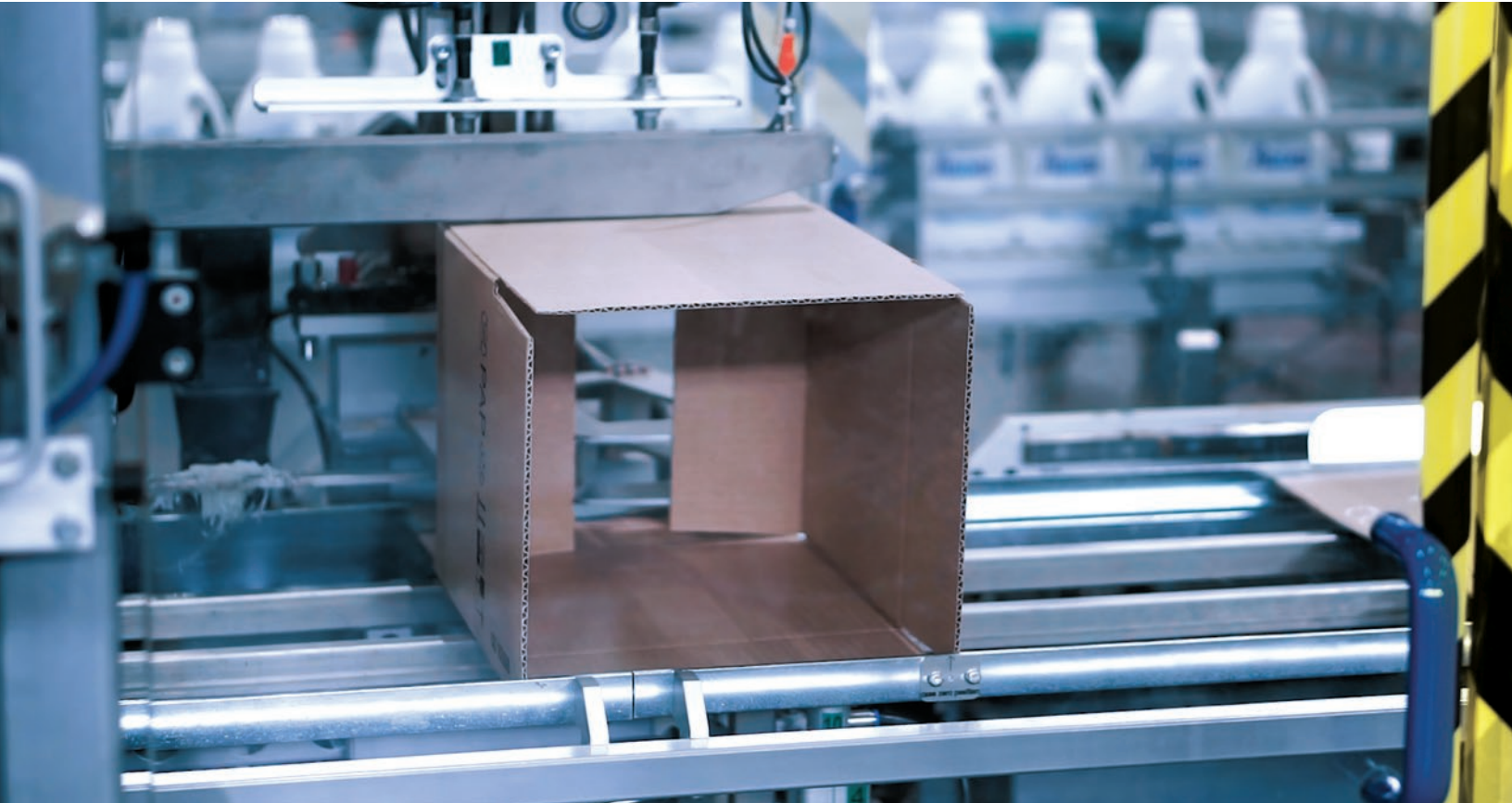

## PREPARE FOR POINT OF SALE

Case packers prepare products for their final journey to the point of sale and protect them in the process. They must be fast but gentle to prevent damage to the contents they pack. More and more of these machines use automated controllers to minimize downtime and improve productivity throughout. Mitsubishi Electric's iQ-R series automation platform is specifically designed to meet those needs with a flexible range of products.

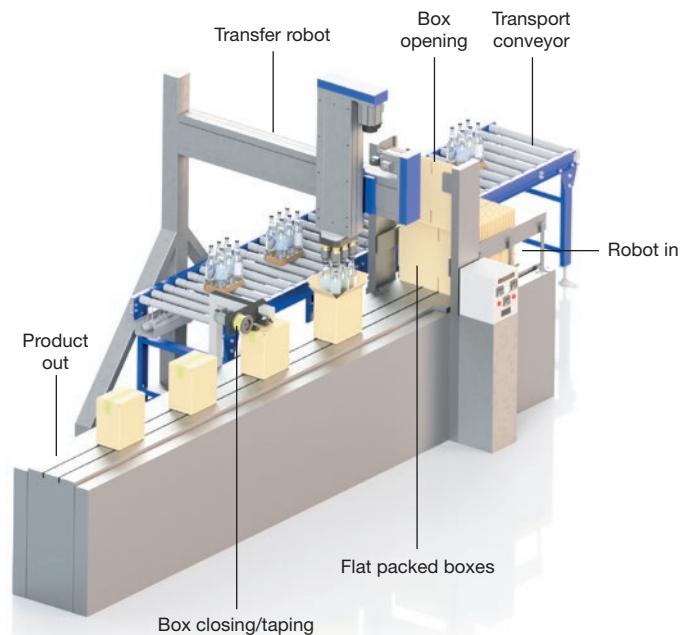

## FAST AND EASY ON ANY NETWORK

Decentralized I/O clearly benefits a machine with such an extensive range of moving components. It cuts down wiring and reduces the hardware required on the control side, which in turn reduces overall machine costs.

Although CC-Link IE TSN is an ideal solution for an effective and highly responsive Ethernet network, the iQ-R series supports nearly all open networks, including EtherNet/IP and EtherCard.

## HIGH SPEED CONTROL WITH SERVO ACCURACY

The iQ-R CC-Link IE TSN motion controller is exceptionally suitable for complex systems with many moving parts. It offers the precise synchronization needed to prevent errors in processes such as box opening, taping, and transfer conveying.



In case packing applications, accuracy is the top priority to avoid product damage. The iQ-R PLC provides a way to interface the system's high-speed components with its many non-servo devices. The iQ-R ensures that all data variants are processed at high speeds without downtime.

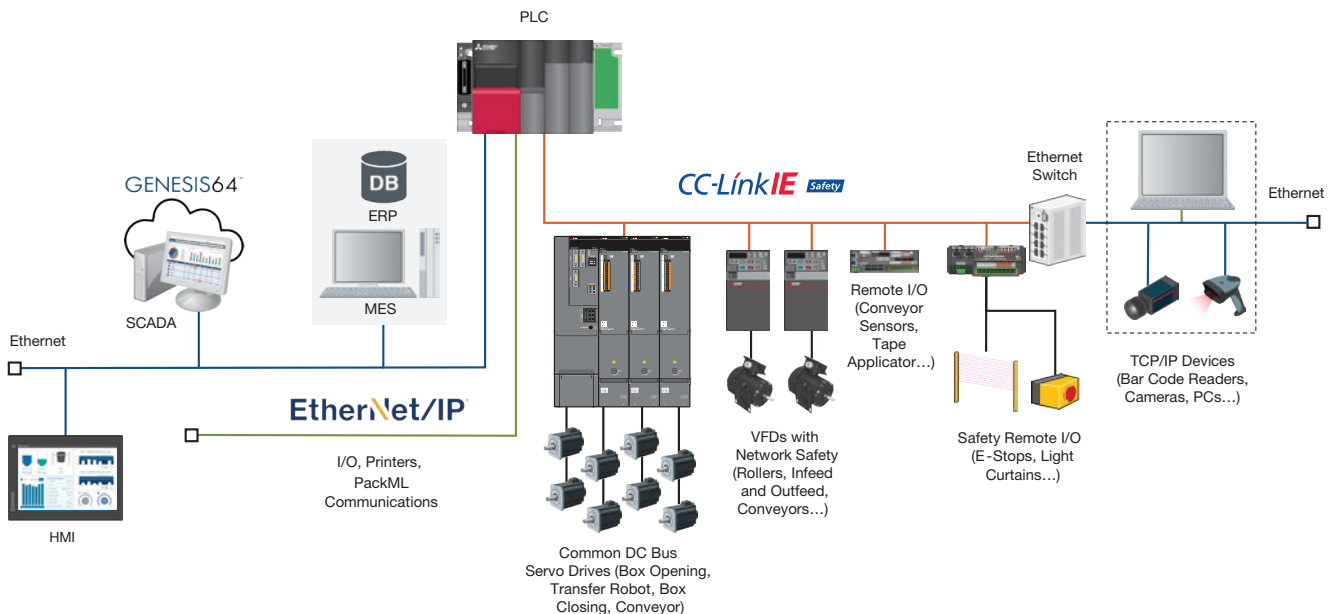

FAST, EFFICIENT, COST-EFFECTIVE

# BAGGING

## PLAIN AND SIMPLE

For simple bagging applications to place a product into a plain bag, pouch or sack, Mitsubishi Electric's iQ-F series PLCs offer a wide range of controllers with simple setup and gentle handling for smooth control and dependable performance.

- PLC open function
- I/O modules
- Ethernet modules

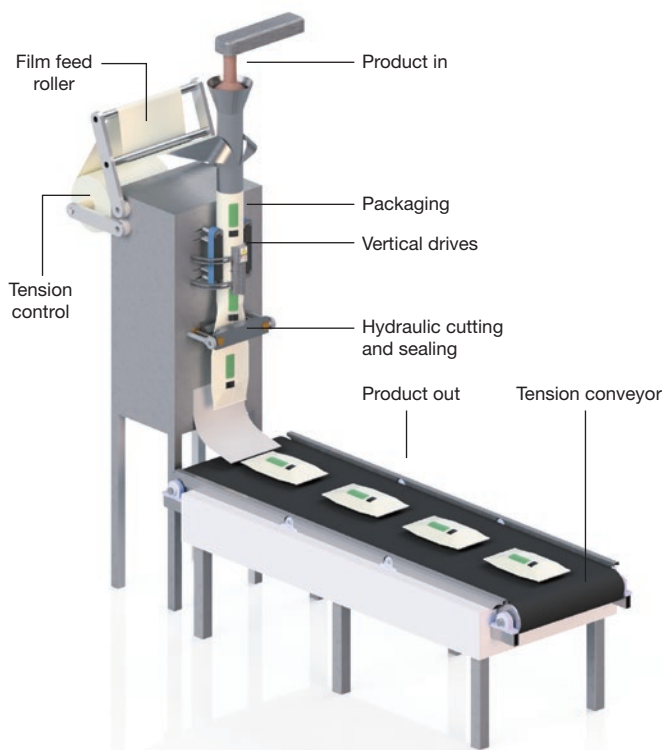

## AS EASY AS 1,2,3

Three components are critical to control a vertical intermittent tubular bagging machine:

- Volume-dosing hardware for product portioning
- Two axes for vertical intermittent motion
- Thermal heat sealing

To coordinate communication between the various devices, Mitsubishi Electric's iQ-F PLC offers a compact solution with room for system expansion.



### 1. SIGNAL

Once the bagger's weighing device confirms the correct product mass, RS485 serial communication or Ethernet signals the iQ-F PLC to allow the process to advance to the next step.

### 2. SYNCHRONIZE

A servo system network using time-sensitive networking technology and the iQ-F CC-Link IE TSN motion controller synchronizes the two independent axes to provide the precise feed control needed to keep bagging material intact.

### 3. SEAL

The iQ-F PLC and temperature controller maintain steady heat levels across the bagger's thermal sealing components. The cross-sealing jaws are moved into place using output control signals from the iQ-F PLC.

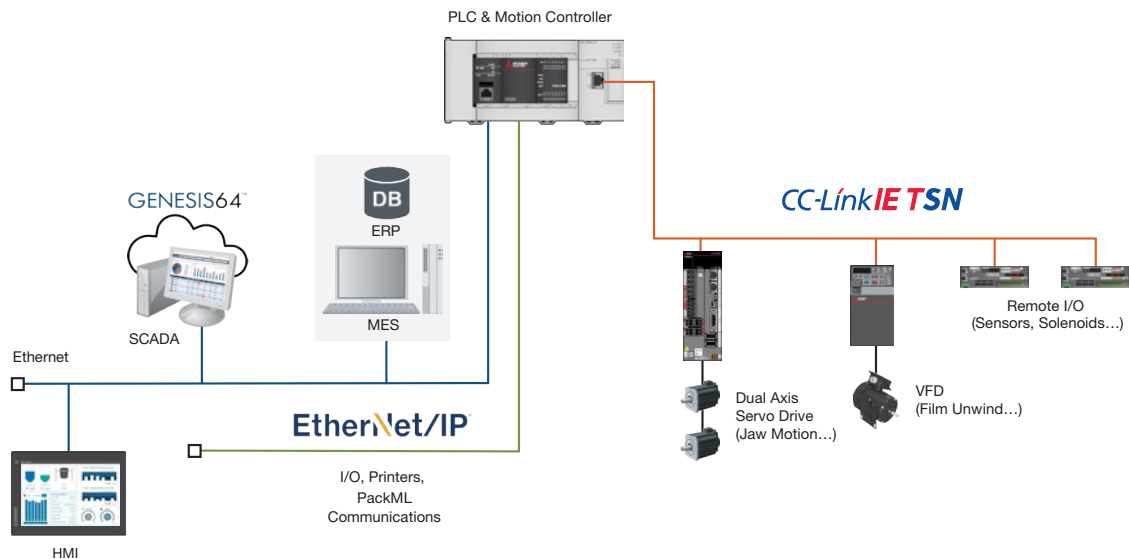

GOOD TO GO

# PALLETIZING



## READYING FOR TRANSPORT

Palletizing and de-palletizing applications ensure that boxed or bagged products are stacked safely and precisely on the pallets, ready for transport to the point of sale. These simple machines don't require extensive servo systems, but must still provide high accuracy while keeping costs low.

That's just what Mitsubishi Electric's iQ-R automation platform, part of the RD78 product family, is designed to do. This complete and flexible solution optimizes performance and reduces costs.

## SMART AND SIMPLE

The RD78 is an intelligent function module ideal for controlling directional axes on the palletizing machine. As an alternative to a motion controller, it provides multiple axes of highly accurate servo control directly from the iQ-R series automation platform. The RD78 is very easy to set up and debug using simple ladder or function block diagram programming and integrated utility software.

The FR-A800 series of Ethernet-capable variable frequency drives is designed for transport conveyors and other types of control. Connecting to the iQ-R series automation platform is simple with CC-Link IE TSN, which can also connect additional devices, such as sensors. With a bandwidth of 1 Gbps, CC-Link IE TSN supplies a high-speed, high-capacity solution while reducing overall system wiring.

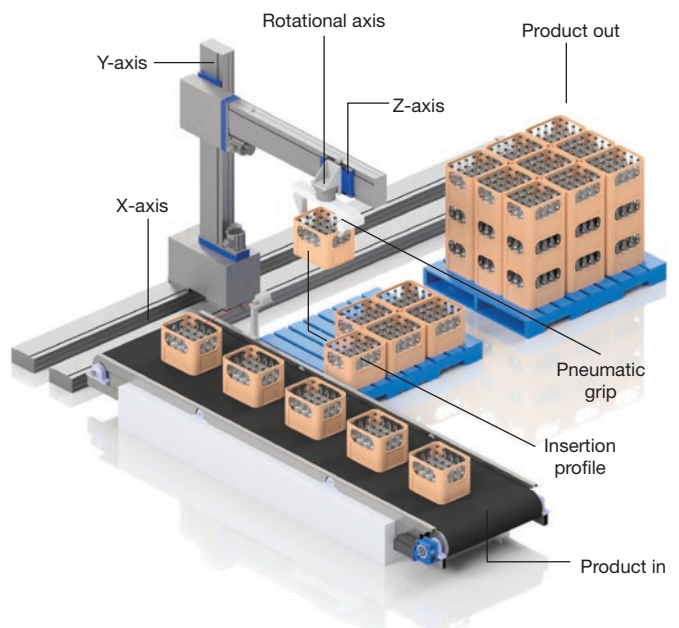

WE'RE WITH YOU ALL THE WAY

# INDUSTRY LEADING TECHNOLOGIES



The iQ-F series (below) delivers high performance in a small panel footprint.

## COMPLETE FLEXIBILITY

Our lineup of fully scalable Programmable Logic Controllers (PLCs) is one of the most flexible in the industry. It supports a wide variety of networks including CC-Link IE TSN, EtherNet/IP, ProfiNet, Modbus, and more. Complex cybersecurity features and tight integration between systems help make Industry 4.0 a reality.

- Complete controller lineup supports any application
- Advanced range of special function modules optimizes application functionality
- Common programming software reduces development time and commissioning costs
- Complex cybersecurity features
- Tight IT & MES integration for Industry 4.0 realization

## COMPLYING WITH INTERNATIONAL QUALITY ASSURANCE STANDARDS

- ISO9001 quality assurance
- ISO14001 environmental management system standards
- UL safety standards
- Various shipping standards



## CC-Link IE TSN

The premier industrial motion control network protocol to run on TSN technology is your connection to everything you need for smart factory solutions.

- IIoT ready
- ONE network for everything
- Fast and powerful
- Easier troubleshooting
- Enhanced diagnostics
- Expansive connectivity

# Contact Mitsubishi Electric to put your solution in motion.



## AMERICAS OFFICES

<b>USA</b> MITSUBISHI ELECTRIC AUTOMATION, INC. 500 Corporate Woods Parkway Vernon Hills, Illinois 60061  Tel : +1- 847.478.2100 Fax : +1- 847.478.2253	<b>Canada</b> MITSUBISHI ELECTRIC AUTOMATION, INC. 4299 14th Avenue Markham, Ontario L3R 0J2  Tel : + 905-754-3805 Fax : (905) 475-7935	<b>Mexico</b> MITSUBISHI ELECTRIC AUTOMATION, INC. Blvd. Miguel de Cervantes Saavedra 301 Col. Ampliación Granada, Miguel Hidalgo CDMX, 11520, México  Tel : +52 (55) 3067-7500
---------------------------------------------------------------------------------------------------------------------------------------------------------------------------	-----------------------------------------------------------------------------------------------------------------------------------------------------------	---------------------------------------------------------------------------------------------------------------------------------------------------------------------------------------------------



[us.MitsubishiElectric.com/fa/en](https://us.MitsubishiElectric.com/fa/en)

**e-Factory**



Mitsubishi Electric's e-F@ctory concept utilizes both FA and IT technologies, through collaboration with e-F@ctory Alliance Partners, to reduce the total cost of development, production, and maintenance, with the aim of achieving manufacturing that is a "step ahead of the times".